

# High Frequency Ceramic Solutions

2.45 GHz Band Pass Filter, SMD, Low Loss and High Attenuation

P/N 2450BP18C100C

Detail Specification: 1/20/2022

Page 1 of 4

General Specifications	
Part Number	2450BP18C100C
Frequency (MHz)	2400 - 2500
Insertion loss (dB)	2.5 max.
Return Loss (dB)	9.5 min.
Ripple (dB)	0.7 min.
Attenuation (dB)	40 min. @ 900 - 928 MHz 30 min. @ 1200 - 1800 MHz 25 min. @ 2100 MHz 35 min. @ 4800 - 5000 MHz 40 min. @ 7200 - 7500 MHz
Impedance ( $\Omega$ )	50
Power Capacity (mW)	500 max. (CW)
Operating Temperature	-40 to +85°C
Reel Quantity (pcs./reel)	3,000

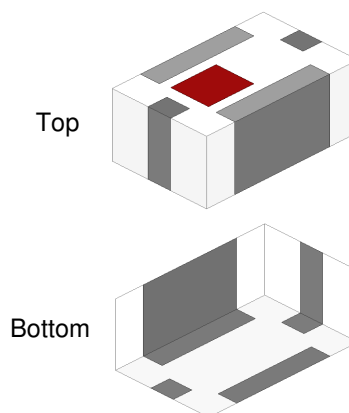

Recommended Storage Conditions and Period for unused Product on T&R	+5 to +35°C
	Humidity 45 - 75% RH 18 months max.

You can download measured s-parameters of this component at: <https://www.johansontechnology.com/band-pass-filters>

## Part Number Explanation

P/N Suffix	Packaging Style	Bulk (loose pcs.)	Suffix = S	E.g. 2450BP18C100CS
		T & R	Suffix = E	E.g. 2450BP18C100CE
	Evaluation Board	50 $\Omega$ SMA	Suffix = EB-SMA	E.g. 2450BP18C100C-EB-SMA

## Mechanical Dimensions

	In	mm
L	0.126 $\pm$ 0.006	3.20 $\pm$ 0.15
W	0.063 $\pm$ 0.006	1.60 $\pm$ 0.15
T	0.037 $\pm$ 0.004	0.95 $\pm$ 0.10
a	0.075 $\pm$ 0.006	1.90 $\pm$ 0.15
b	0.020 $\pm$ 0.006	0.50 $\pm$ 0.15
c	0.012 $\pm$ 0.008	0.30 $\pm$ 0.20
d	0.026 $\pm$ 0.008	0.65 $\pm$ 0.20

## Terminal Configuration

No.	Function
1	GND
2	INPUT / OUTPUT
3	GND
4	INPUT / OUTPUT

Johanson Technology, Inc. reserves the right to make design changes without notice.

All sales are subject to Johanson Technology, Inc. terms and conditions.



Ver. 2.0

<https://www.johansontechnology.com>

4001 Calle Tecate • Camarillo, CA 93012, USA • TEL +1.805.389.1166

2022 Johanson Technology, Inc. All Rights Reserved

# High Frequency Ceramic Solutions

2.45 GHz Band Pass Filter, SMD, Low Loss and High Attenuation

P/N 2450BP18C100C

Detail Specification: 1/20/2022

Page 2 of 4

## Mounting Considerations

Mount these devices with brown mark facing up.

Units in mm

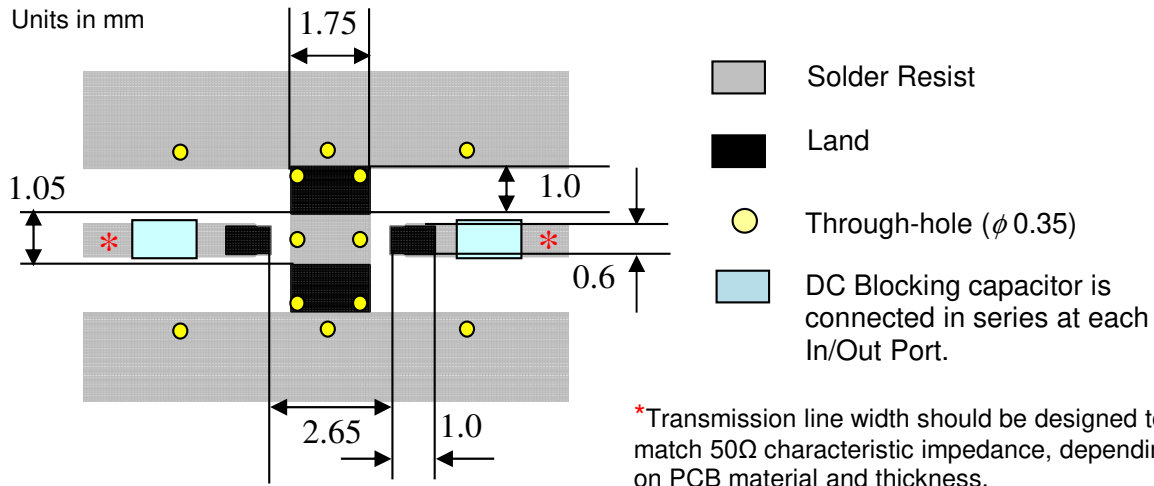

Would you like the layout? Send us a message at: <https://www.johansontechnology.com/ask-a-question>

## Measuring Diagram

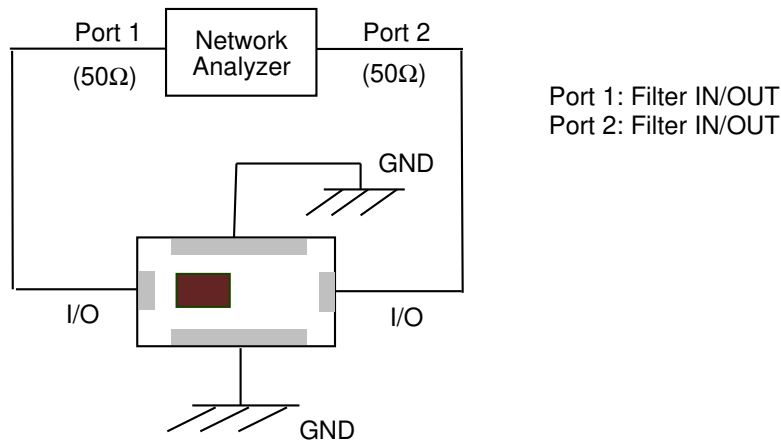

Johanson Technology, Inc. reserves the right to make design changes without notice.

All sales are subject to Johanson Technology, Inc. terms and conditions.



Ver. 2.0

<https://www.johansontechnology.com>

4001 Calle Tecate • Camarillo, CA 93012, USA • TEL +1.805.389.1166

2022 Johanson Technology, Inc. All Rights Reserved

# High Frequency Ceramic Solutions

2.45 GHz Band Pass Filter, SMD, Low Loss and High Attenuation

P/N 2450BP18C100C

Detail Specification: 1/20/2022

Page 3 of 4

## Typical Electrical Characteristics (T=25°C)

### Insertion Loss & Return loss

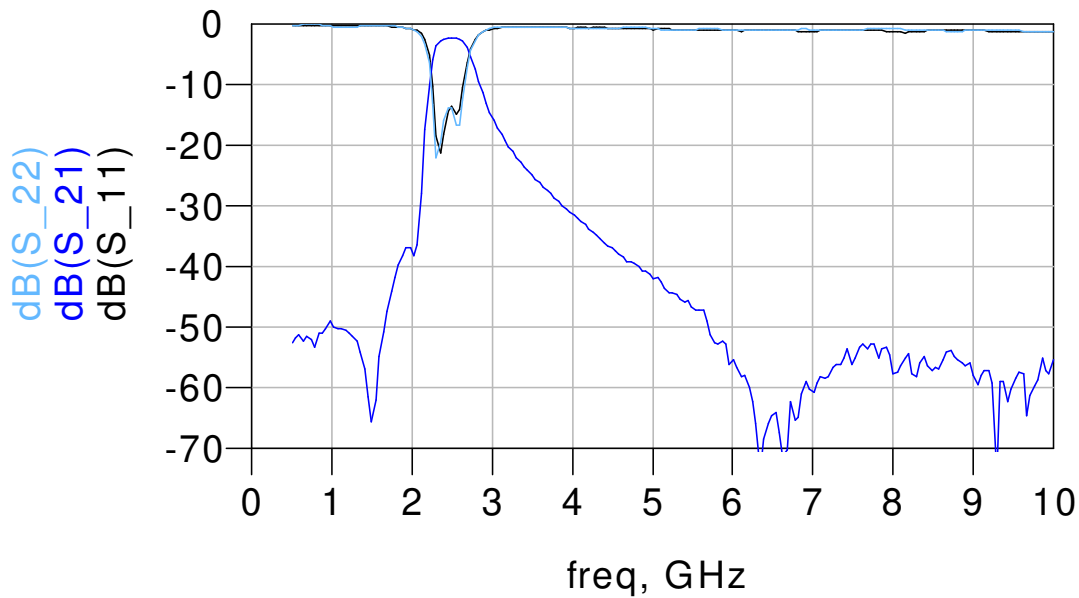

Johanson Technology, Inc. reserves the right to make design changes without notice.

All sales are subject to Johanson Technology, Inc. terms and conditions.



Ver. 2.0

<https://www.johansontechnology.com>

4001 Calle Tecate • Camarillo, CA 93012, USA • TEL +1.805.389.1166

2022 Johanson Technology, Inc. All Rights Reserved

# High Frequency Ceramic Solutions

2.45 GHz Band Pass Filter, SMD, Low Loss and High Attenuation

P/N 2450BP18C100C

Detail Specification: 1/20/2022

Page 4 of 4

## Application Notes, Layout Files, and more

<https://www.johansontechnology.com/band-pass-filters>

## Packaging information

<https://www.johansontechnology.com/tape-reel-packaging>

## Soldering Information

<https://www.johansontechnology.com/ipcsoldering-profile>

## MSL Info

<https://www.johansontechnology.com/msl-rating>

## Recommended Storage Condition and Max Shelf Life

<https://www.johansontechnology.com/recommended-storage-conditions>

## RoHS Compliance

<https://www.johansontechnology.com/rohs-compliance>

## Antenna layout and tuning techniques

<https://www.johansontechnology.com/tuning>

## Antenna layout review, tuning, and characterization services

<https://www.johansontechnology.com/ipc-antenna-services>

Johanson Technology, Inc. reserves the right to make design changes without notice.

All sales are subject to Johanson Technology, Inc. terms and conditions.



Ver. 2.0

<https://www.johansontechnology.com>

4001 Calle Tecate • Camarillo, CA 93012, USA • TEL +1.805.389.1166

2022 Johanson Technology, Inc. All Rights Reserved