

# "High Frequency Ceramic Solutions"

**Mini Passive RF Diplexer 2.4/5.4GHz for 802.11-WLAN-WiFi**  
**EIA 0603 with LPF/BPF Filtering Scheme**

**P/N 2450DP14G5400**

Detail Specification: 5/17/2017

Page 1 of 3

Not exactly what you are looking for and want to see our other diplexers? Go to: [www.johansontechnology.com/diplexers](http://www.johansontechnology.com/diplexers)

| General Specifications     |  |
|----------------------------|--|
| <b>Part Number</b>         | 2450DP14G5400                                    |
| <b>Passband (MHz)</b>      | 2400~2500      4900~5950                         |
| <b>Insertion Loss (dB)</b> | 0.58dB typ. (0.75 max.)      0.8 typ. (1.1 max.) |
| <b>Attenuation I (db)</b>  | 25 min. @ 4.8-5.0 GHz      20 min. @ 1.8-2.5 GHz |
| <b>Attenuation II (db)</b> | 20 min. @ 7.2-7.5GHz      15 min. @ 9.8-11.9GHz  |
| <b>Return Loss</b>         | 9.5 dB min.      9.5 dB min.                     |
| <b>Power Capacity</b>      | 2W max. (CW)                                     |
| <b>Storage Period</b>      | 18 months max.                                   |
| <b>Reel Quantity</b>       | 4,000  |

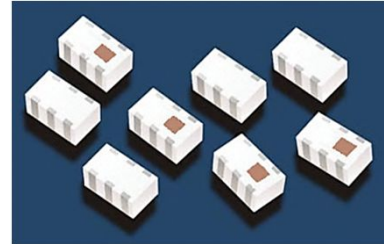

|                        |               |
|------------------------|---------------|
| <b>Operating Temp.</b> | -40 to +85 °C |
| <b>Storage Temp.</b>   | -40 to +85 °C |

| Mechanical Dimensions |                     |                |
|-----------------------|---------------------|----------------|
|                       | In                  | mm             |
| <b>L</b>              | 0.063 ± 0.004       | 1.6 ± 0.1      |
| <b>W</b>              | 0.031 ± 0.004       | 0.8 ± 0.1      |
| <b>T</b>              | 0.024 ± 0.004       | 0.6 ± 0.1      |
| <b>a</b>              | 0.008 ± 0.004       | 0.2 ± 0.1      |
| <b>b</b>              | 0.008 ± 0.004/0.006 | 0.2 ± 0.1/0.15 |
| <b>c</b>              | 0.006 ± 0.004       | 0.15 ± 0.1     |
| <b>g</b>              | 0.012 ± 0.004       | 0.3 ± 0.1      |
| <b>p</b>              | 0.020 ± 0.002       | 0.5 ± 0.05     |

| Terminal Configuration |                         |          |             |
|------------------------|-------------------------|----------|-------------|
| No.                    | Function                | No.      | Function    |
| <b>1</b>               | Low Freq (2.45GHz) Band | <b>4</b> | GND         |
| <b>2</b>               | GND                     | <b>5</b> | Common Port |
| <b>3</b>               | High Freq (5.4GHz) Band | <b>6</b> | GND         |

| Part Number Explanation |                          |                      |               |                           |
|-------------------------|--------------------------|----------------------|---------------|---------------------------|
| <b>P/N Suffix</b>       | <b>Packing Style</b>     | Bulk                 | Suffix = S    | eg. 2450DP14G5400S        |
|                         |                          | T & R                | Suffix = T    | eg. 2450DP14G5400T        |
|                         | <b>Termination style</b> | 100% Tin             | Suffix = None | eg. 2450DP14G5400(T or S) |
|                         | <b>Evaluation Board</b>  | 2450DP14G5400-EB1SMA |               |                           |

Would you like the layout file for component? Please send us as message at: [www.johansontechnology.com/ask-a-question](http://www.johansontechnology.com/ask-a-question)

### Mounting Considerations

- Solder Resist
- Land
- Through-hole (φ 0.35)

\* Line width should be designed to match 50Ω characteristic impedance (CPWG proffered), depending on PCB material and thickness.

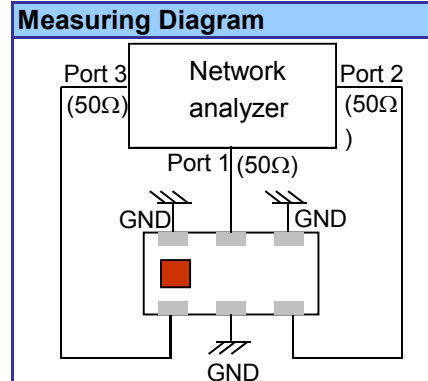

4001 Calle Tecate • Camarillo, CA 93012 • TEL 805.389.1166 FAX 805.389.1821

Ver. 1.1

2017 Johanson Technology, Inc. All Rights Reserved

[www.johansontechnology.com](http://www.johansontechnology.com)

# "High Frequency Ceramic Solutions"

Mini Passive RF Diplexer 2.4/5.4GHz for 802.11-WLAN-WiFi  
EIA 0603 with LPF/BPF Filtering Scheme

P/N 2450DP14G5400

Detail Specification: 5/17/2017

Page 2 of 3

## Typical Electrical Characteristics (T=25 °C)

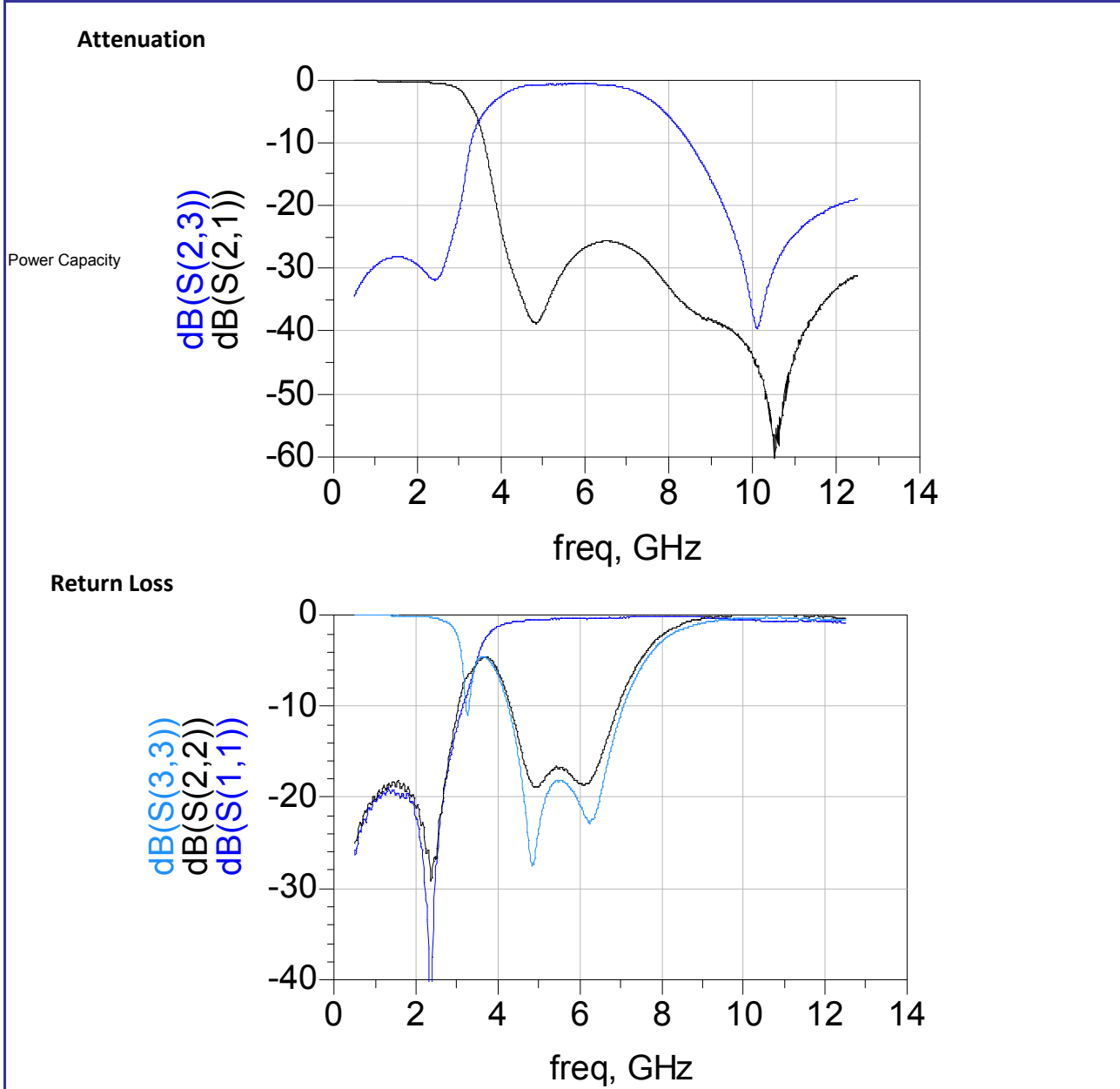

The contents of this data sheet are subject to change without notice. Please confirm the specifications and delivery conditions when placing your order. All sales are subject to Johanson Technology, Inc. terms and conditions.



# "High Frequency Ceramic Solutions"

**Mini Passive RF Diplexer 2.4/5.4GHz for 802.11-WLAN-WiFi  
EIA 0603 with LPF/BPF Filtering Scheme**

**P/N 2450DP14G5400**

Detail Specification: 5/17/2017

Page 3 of 3

## RoHS Compliance

[www.johansontechnology.com/rohs-compliance](http://www.johansontechnology.com/rohs-compliance)

## Packaging information

[www.johansontechnology.com/tape-reel-packaging](http://www.johansontechnology.com/tape-reel-packaging)

## Soldering Information

[www.johansontechnology.com/ipcsoldering-profile](http://www.johansontechnology.com/ipcsoldering-profile)

## Power Capacity

[www.johansontechnology.com/ask-a-question](http://www.johansontechnology.com/ask-a-question)

## MSL Info

[www.johansontechnology.com/msl-rating](http://www.johansontechnology.com/msl-rating)

## Recommended Storage Condition and Max Shelf Life

[www.johansontechnology.com/recommended-storage-conditions](http://www.johansontechnology.com/recommended-storage-conditions)

## Antenna layout and tuning techniques

[www.johansontechnology.com/tuning](http://www.johansontechnology.com/tuning)

## Antenna layout review, tuning, and characterization services

[www.johansontechnology.com/ipc-antenna-services](http://www.johansontechnology.com/ipc-antenna-services)

## Recommended Storage Conditions for uninstalled product on T&R.

+5 to +35 °C, Humidity 45~75%RH

The contents of this data sheet are subject to change without notice. Please confirm the specifications and delivery conditions when placing your order. All sales are subject to Johanson Technology, Inc. terms and conditions.



Ver. 1.1

[www.johansontechnology.com](http://www.johansontechnology.com)

4001 Calle Tecate • Camarillo, CA 93012 • TEL 805.389.1166 FAX 805.389.1821

2017 Johanson Technology, Inc. All Rights Reserved