

# High Frequency Ceramic Solutions

**Triplexer 1.5/2.4/5.5GHz for GPS/GLNSS/BLE/802.11/WLAN/WiFi P/N 1590TP15A5500**

Detail Specification: 01/03/2014

Page 1 of 3

General Specifications			
<b>Input (or output)</b>	50Ω Single Ended		
<b>Output (or Input) Frequencies</b>	1560-1606 MHz	2400- 2500 MHz	4900-5950 MHz
<b>Insertion Loss</b>	0.9 dB max.	1.1 dB max.	1.0 dB max.
<b>Return Loss</b>	10 dB min.	10 dB min.	10 dB min.
<b>Attenuation (dB)</b>	15 min. @ 2400 ~ 2500 MHz	25 min. @ 1560 ~ 1606 MHz	20 min. @ 1560 ~ 1606 MHz
	20 min. @ 4900 ~ 5950 MHz	20 min. @ 4900 ~ 5950 MHz	25 min. @ 2400 ~ 2500 MHz
	15 min. @ 9800 ~ 11900 MHz		
<b>Operating Temperature</b>	-40 to +85°C		
<b>Q'ty/Reel (pcs)</b>	4,000		
<b>Storage Period</b>	18 months max.		
<b>Power Capacity</b>	2W max.(CW)		
<b>Bi-Directionality</b>	This is a fully bi-directional passive device, all ports behave as I/Os.		
If the designer wants to use one or two port(s) instead of all three, make sure to 50Ω-terminate the unused port(s)			



Mechanical Dimensions		
	In	mm
L	0.079 ± 0.004	2.00 ± 0.10
W	0.049 ± 0.004	1.25 ± 0.10
T	0.037 ± 0.004	0.95 ± 0.10
a	0.012 ± 0.004	0.30 ± 0.10
b	0.008 ± 0.004	0.20 ± 0.10
c	0.012 ± 0.004/-0.008	0.30 ± 0.1/-0.2
g	0.014 ± 0.004	0.35 ± 0.10
p	0.026 ± 0.002	0.65 ± 0.05

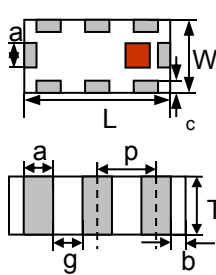

Terminal Configuration			
No	Function	No	Function
1	GND	5	GND
2	Common Port	6	2.4GHz Band Port
3	GND	7	GND
4	5.5GHz Band Port	8	1.5GHz Band Port

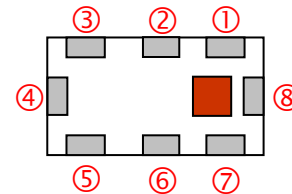

Ordering Information			
<b>P/N Suffix</b>	<b>Packing Style</b>	Bulk	Suffix = S eg. 1590TP15A5500S
		T & R	Suffix = E eg. 1590TP15A5500E
	<b>Evaluation Board (3xSMA female connectors, 50Ω)</b>		1590TP15A5500-EB1SMA

Johanson Technology, Inc. reserves the right to make design changes without notice.  
All sales are subject to Johanson Technology, Inc. terms and conditions.



[www.johansontechnology.com](http://www.johansontechnology.com)  
4001 Calle Tecate • Camarillo, CA 93012 • TEL 805.389.1166 FAX 805.389.1821

Ver 1.1

2014 Johanson Technology, Inc. All Rights Reserved

# High Frequency Ceramic Solutions

**Triplexer 1.5/2.4/5.5GHz for GPS/GLNSS/BLE/802.11/WLAN/WiFi** P/N 1590TP15A5500

Detail Specification: 01/03/2014

Page 2 of 3

## Mounting Considerations

All Units in mm

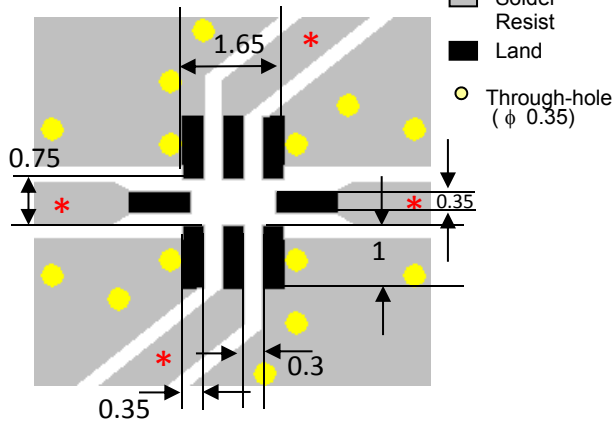

\*Line width should be designed to match 50 $\Omega$  characteristic impedance, which will depend on PCB material, GND thickness.

The above PCB is orderable! p/n: 1590TP15A5500-EB1SMA

## Measuring Diagram for mass production measurements and S-Parameter Characterization

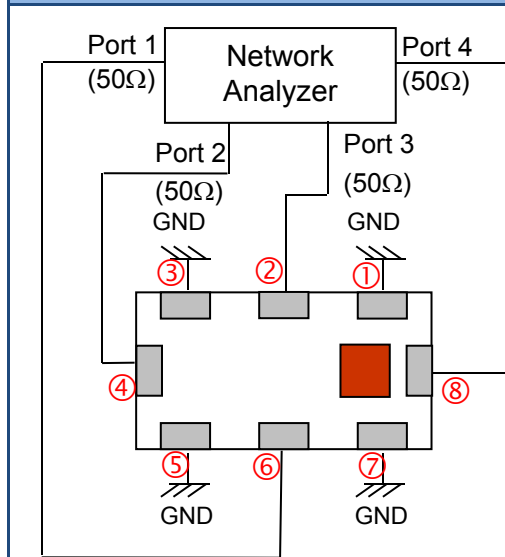

## Typical Electrical Characteristics (T=25° C)

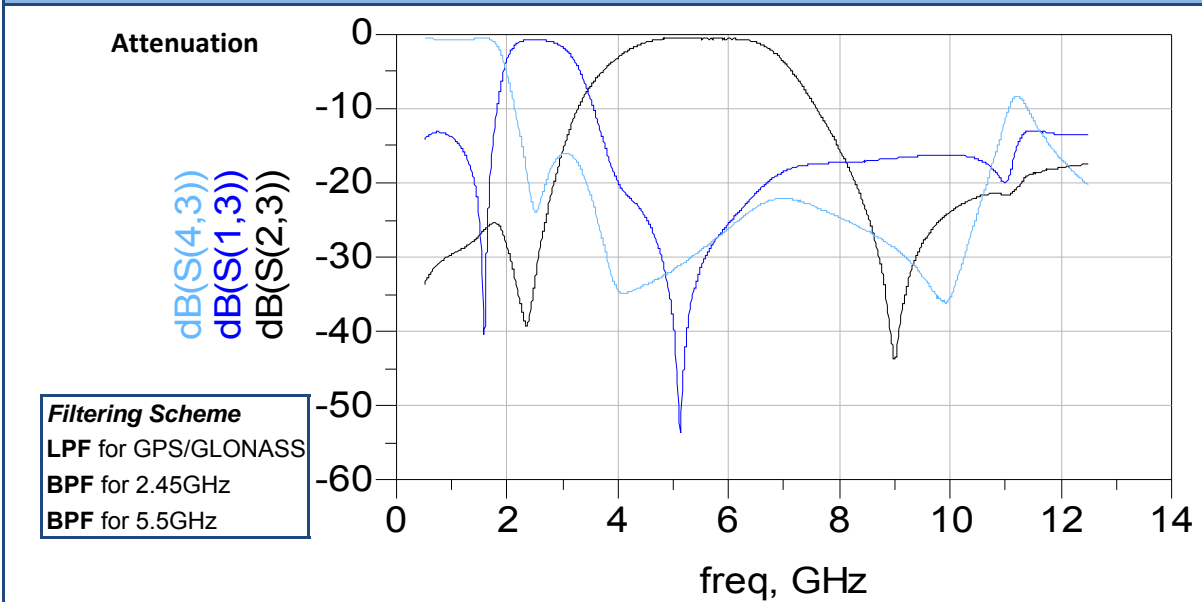

Johanson Technology, Inc. reserves the right to make design changes without notice.  
 All sales are subject to Johanson Technology, Inc. terms and conditions.



# High Frequency Ceramic Solutions

Triplexer 1.5/2.4/5.5GHz for GPS/GLNSS/BLE/802.11/WLAN/WiFi

P/N 1590TP15A5500

Detail Specification: 01/03/2014

Page 3 of 3

## Typical Electrical Performance (T=25°C)

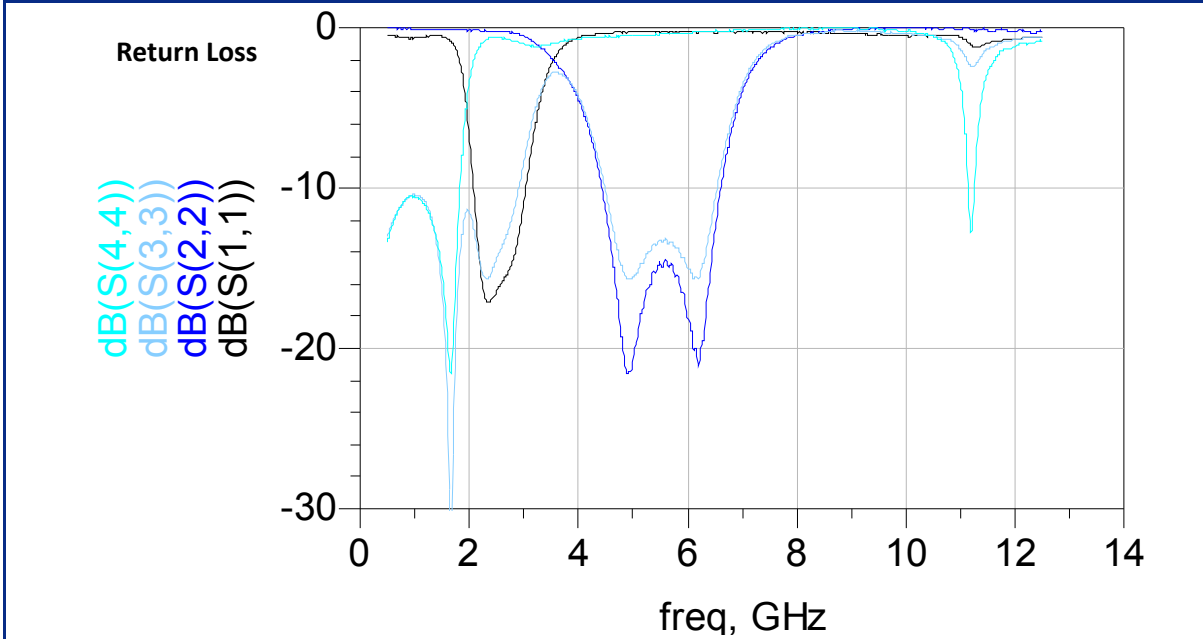

## Packaging information

[www.johansontechnology.com/ipcpackaging.html](http://www.johansontechnology.com/ipcpackaging.html)

## Soldering Information

[www.johansontechnology.com/ipcsoldering-profile](http://www.johansontechnology.com/ipcsoldering-profile)

## RoHS Compliance

[www.johansontechnology.com/technical-notes/rohs-compliance.html](http://www.johansontechnology.com/technical-notes/rohs-compliance.html)

## MSL Info

[www.johansontechnology.com/technical-notes/msl-rating.html](http://www.johansontechnology.com/technical-notes/msl-rating.html)

## To Download Measured S-parameters for Evaluation and Simulation:

[www.johansontechnology.com/triplexers](http://www.johansontechnology.com/triplexers)

## For layout review or any other technical questions, please contact our Applications Team at:

[www.johansontechnology.com/component/techquestion?Itemid=407](http://www.johansontechnology.com/component/techquestion?Itemid=407)

Johanson Technology, Inc. reserves the right to make design changes without notice.

All sales are subject to Johanson Technology, Inc. terms and conditions.



4001 Calle Tecate • Camarillo, CA 93012 • TEL 805.389.1166 FAX 805.389.1821  
Ver 1.1

[www.johansontechnology.com](http://www.johansontechnology.com)

2014 Johanson Technology, Inc. All Rights Reserved