

5.4 GHz RF 1:2 Balun

- 4900 - 5875 MHz, 50:100 (1:2) Impedance Ratio
- Wireless communication systems including: WiFi, 802.11, Public Safety, UNII, PtP, ISM
- SMD, EIA 0805
- RoHS compliant

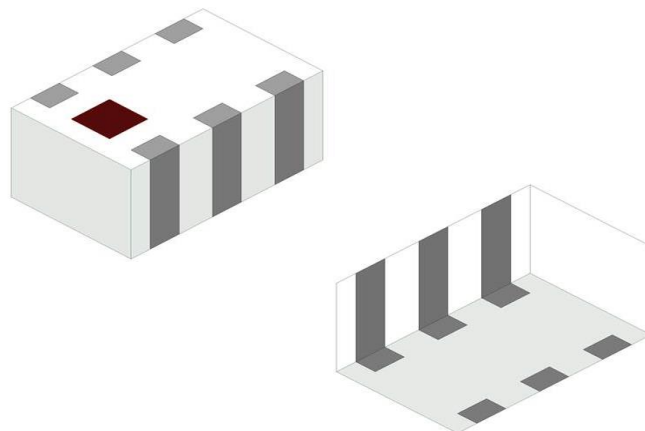

General Specifications^{1 2}

Passband Frequency (MHz)	4900 – 5875
Unbalanced Impedance (Ω)	50
Balanced Impedance (Ω)	100
Insertion Loss (dB)	1.0 Max.
Return Loss (dB)	9.5 Min.
Phase Difference (degree)	180 \pm 10
Amplitude Difference (dB)	2 Max.

Maximum Ratings

Power Capacity (W)	2 Max. (CW)
Operating Temperature ($^{\circ}$ C)	-40 to +85
Recommended Storage Conditions post-installation ($^{\circ}$ C)	-40 to +85
Recommended Storage Conditions and Period for Unused T&R Product	45% - 75% RH +5 to +35 $^{\circ}$ C 18 Months Max.

¹ Typical value represents average measurement at 25 $^{\circ}$ C. Min./Max. values represent measurements over specified operating temperature.

² General specifications measured on Johanson's evaluation board P/N 5400BL15B0100001CE1.

Mechanical Dimensions

	Inches			Millimeters		
L	0.079	±	0.004	2.00	±	0.10
W	0.049	±	0.004	1.25	±	0.10
T	0.037	±	0.004	0.95	±	0.10
a	0.012	±	0.004	0.30	±	0.10
b	0.008	±	0.004	0.20	±	0.10
c	0.012	+0.004/-	0.008	0.30	+0.1/-	0.2
g	0.014	±	0.004	0.35	±	0.10
p	0.026	±	0.002	0.65	±	0.05

Bottom view

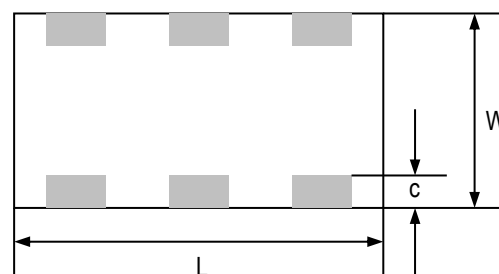

Side view

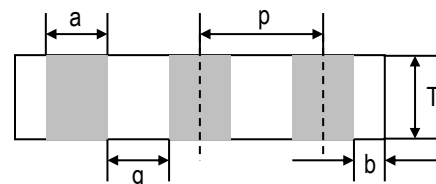

Terminal Configuration³

Pin Number	Function
1	Unbalanced Port (IN)
2 ⁴	GND or (DC feed + RF GND)
3	Balanced Port (OUT1)
4	Balanced Port (OUT2)
5	GND
6	NC

Top view

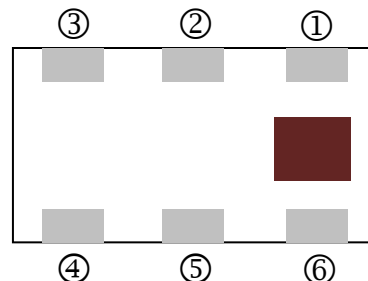

³ The termination type is Nickel Tin. Go to: <https://www.johansontechnology.com/tech-notes/typical-soldering-profile-ipc> for Typical Soldering Profile.

⁴ Use 1.5pF RF GND cap when using DC-Feed option.



Recommended PCB Layout

Note: Mount device with colored mark facing up.

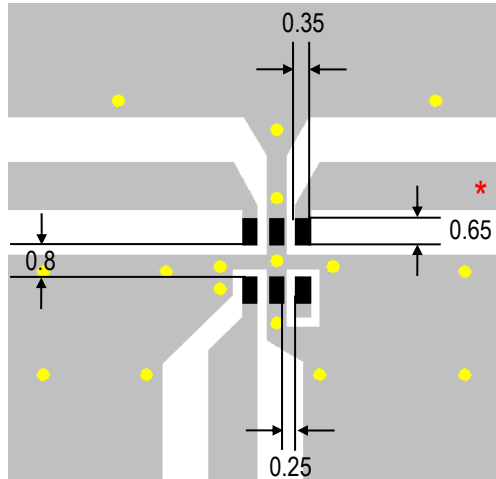
Without DC feed





Units: mm

-  Solder Resist
-  Land
-  Through-hole ($\phi 0.3$)

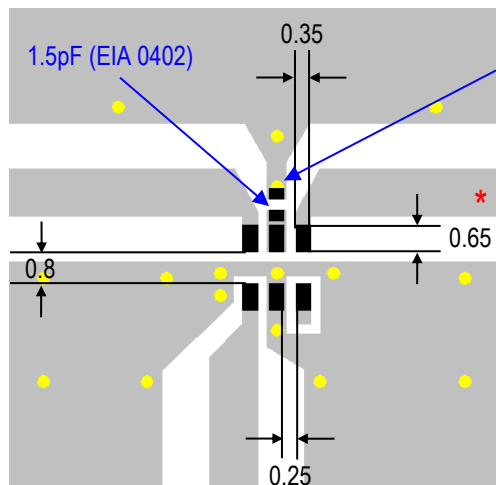
With DC feed⁵



-  Solder Resist
-  Land
-  Through-hole ($\phi 0.3$)

*Transmission line width should be designed to match 50Ω characteristic impedance, depending on PCB material and thickness.

If you would like the full reference design package or have any questions, contact our application engineers at <https://www.johansontechnology.com/ask-a-question>

⁵ When using this balun in a DC bias configuration, a bypass capacitor is required to shunt RF signals to ground. Be aware that due to this added bypass capacitor, there is a longer path to ground that contributes to increased imbalance between the differential paths. We recommend that the GND via be placed as close as possible to the bypass capacitor to minimize this effect.

Equivalent Internal Circuit^{6 7 8}

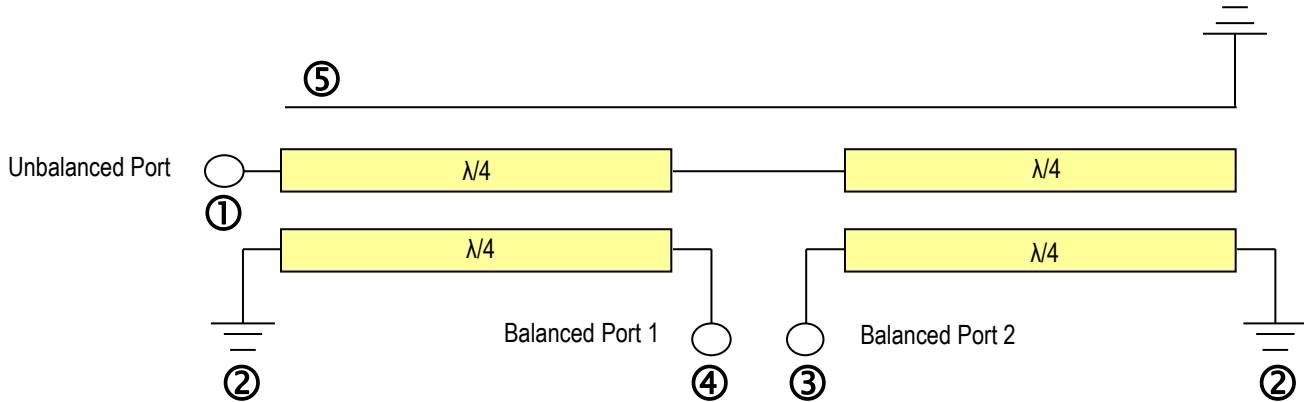

Measuring Diagram

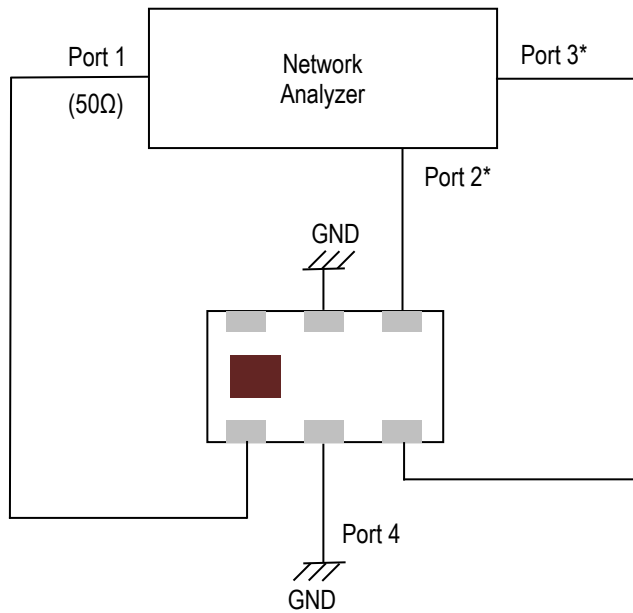

Port 1: Unbalanced Port

Ports 2 and 3: Balanced Port

Port 4: GND or DC feed + RF GND

Insertion Loss = S_{ds21}

Return Loss = S_{ss11}

Amplitude Balance = $\text{dB}(S(2,1)/S(3,1))$

Phase Balance = $\text{Phase}(S(2,1)/S(3,1))$

*Impedance for Ports 2 and 3 = Balanced Impedance/2

⁶ Pin3 and Pin4 are DC connected to Pin2 (GND or DC feed) in the device but not DC connected to Pin5 (GND). Therefore, by-pass capacitors should be connected when feeding DC power from Pin2. Recommended bypass capacitor: 1.5pF (EIA 0402).

⁷ Unbalanced port does not have a direct current path to GND.

⁸ Pin 6 is a floating pin (no internal connections) but it still must be soldered.

RF Measurement (T=25°C)

Insertion Loss and Return Loss

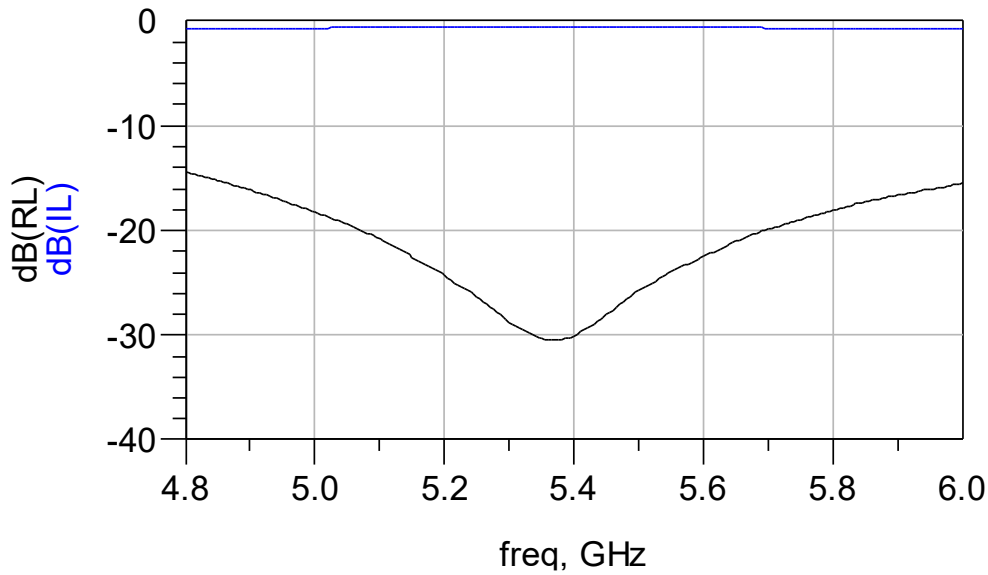

Phase Difference and Amplitude Difference

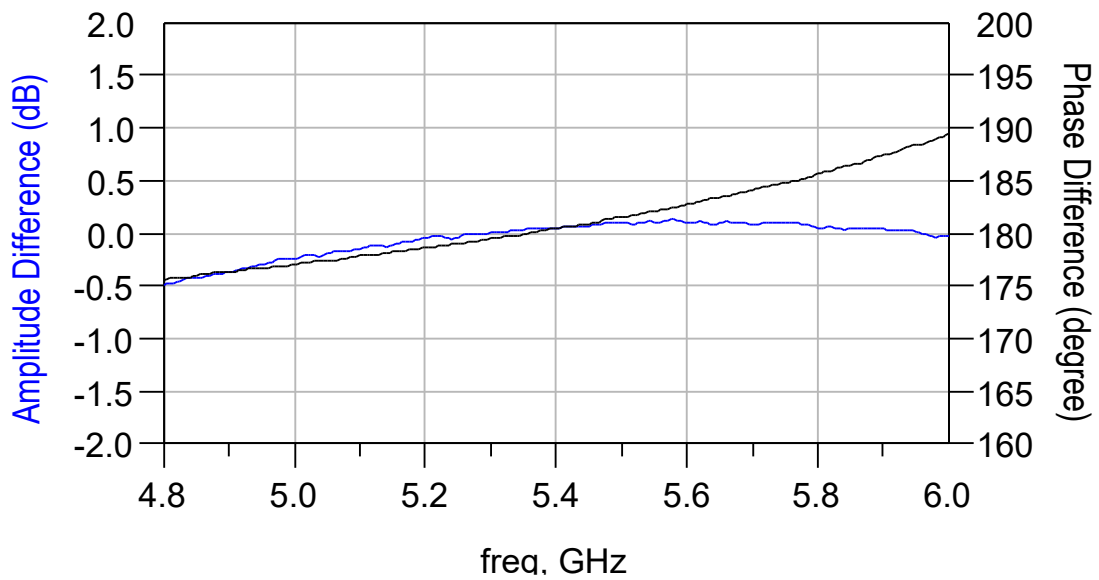

S-parameter and layout files available upon request. Please contact us at <https://www.johansontechnology.com/ask-a-question>

Tape and Reel Specification (Units in mm)

Tape Dimensions

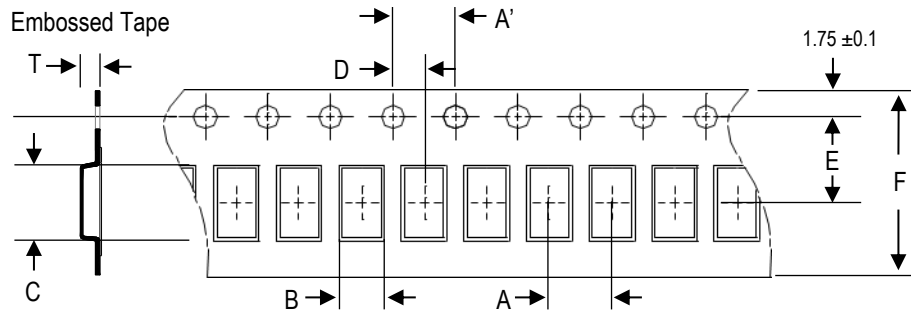

A	A'	B	C	D	E	F	T	Quantity/reel	Tape material
4.0 ±0.1	4.0 ±0.1	1.35 ±0.05	2.15 ±0.05	2.0 ±0.05	3.5 ±0.1	8.0 ±0.1	1.08 ±0.05	4,000 pcs.	Plastic (Embossed)

Reel Dimensions

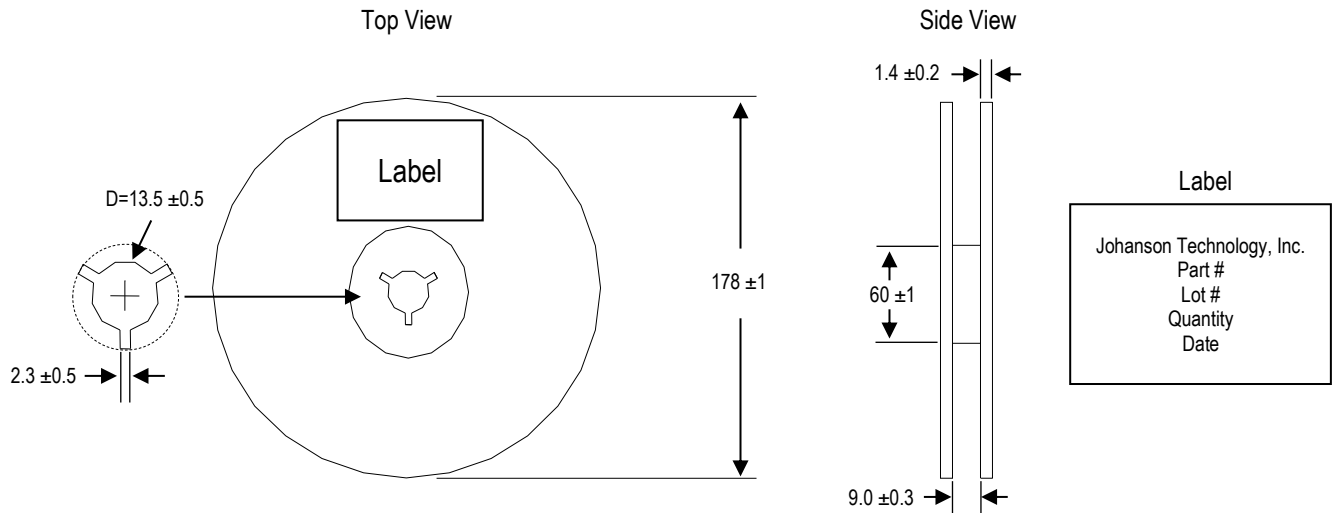

Leader and Trailer Dimensions

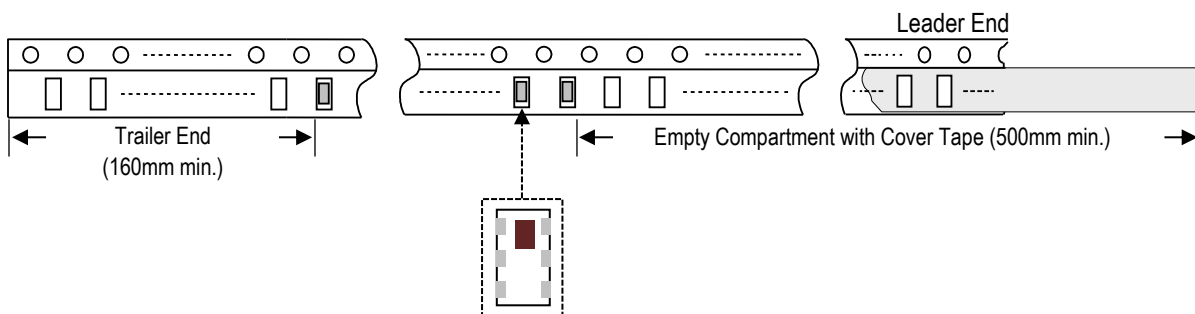

Orderable Part Number

Packaging Style	Part Number	Termination
Bulk (loose pcs.)	5400BL15B0100001B	Nickel Tin
T & R (7" Reel Embossed Tape)	5400BL15B0100001E (Qty: 4,000 pcs./reel)	
Evaluation Board with 3 SMA Connectors	5400BL15B0100001CE1	

Important Links

[5400BL15B0100001E Product Page](#)

[More RF Baluns](#)

[Antenna Tuning, Optimization, and Validation Services](#)

[Soldering Information](#)

[MSL Information](#)

[Packaging Information](#)

[Recommended Storage Condition and Max Shelf Life](#)

[RoHS Compliance](#)

**Johanson Technology, Inc. reserves the right to make design changes without notice.
All sales are subject to Johanson Technology, Inc. terms and conditions.**