

6.75 GHz RF 1:1 Balun

- 5000 - 8500 MHz, 50:50 (1:1) Impedance Ratio
- Wireless communication systems Ultra-wide Band (UWB), including UNII
- SMD, EIA 0603
- RoHS compliant

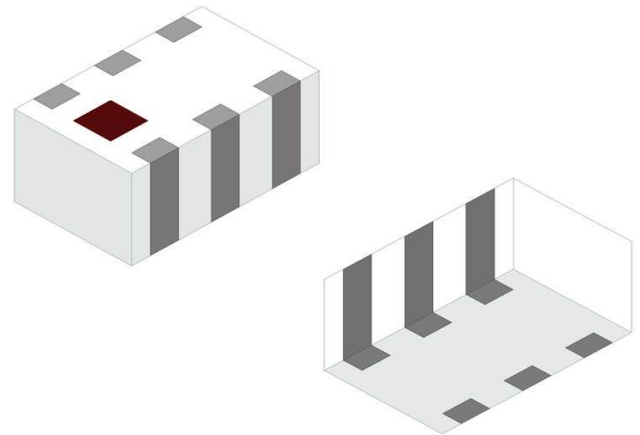

General Specifications^{1 2}

Passband Frequency (MHz)	5000 – 8500
Unbalanced Impedance (Ω)	50
Balanced Impedance (Ω)	50
Insertion Loss (dB)	0.7 Typ. (1.5 Max.)
Return Loss (dB)	14.5 Typ. (9.5 Min.)
Phase Difference (degree)	180 ± 13
Amplitude Difference (dB)	± 1.25
CMRR (dB)	17.5 Min.

Maximum Ratings

Power Capacity (W)	3 Max. (CW)
DC Feed Current Rating (A)	1 Max.
Operating Temperature ($^{\circ}\text{C}$)	-40 to +85
Recommended Storage Conditions post-installation ($^{\circ}\text{C}$)	-40 to +85
Recommended Storage Conditions and Period for Unused T&R Product	45% - 75% RH +5 to +35 $^{\circ}\text{C}$ 18 Months Max.

¹ Typical value represents average measurement at 25 $^{\circ}\text{C}$. Min./Max. values represent measurements over specified operating temperature.

² General specifications measured on Johanson's evaluation board P/N 6750BL14A0050001CE1.

Mechanical Dimensions

	Inches			Millimeters		
L	0.063	±	0.004	1.60	±	0.10
W	0.031	±	0.004	0.80	±	0.10
T	0.024	±	0.004	0.60	±	0.10
a	0.008	±	0.004	0.20	±	0.10
b	0.008	±	0.006	0.20	±	0.15
c	0.006	±	0.004	0.15	±	0.10
g	0.012	±	0.004	0.30	±	0.10
p	0.020	±	0.002	0.50	±	0.05

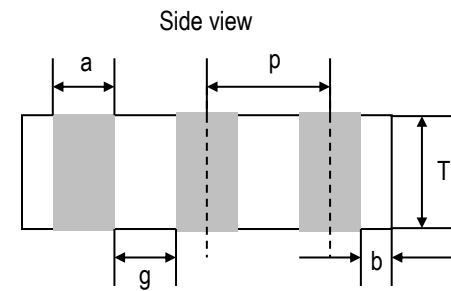
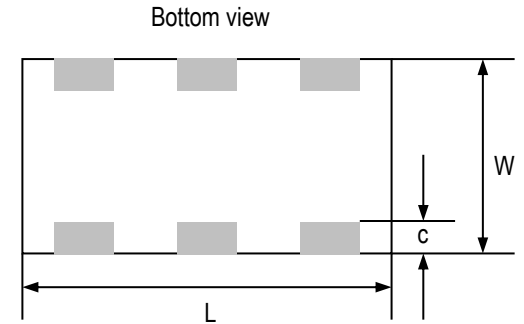

Terminal Configuration³

Pin Number	Function
1	Unbalanced Port (IN)
2 ⁴	GND or (DC feed + RF GND)
3	Balanced Port (OUT1)
4	Balanced Port (OUT2)
5	GND
6	NC

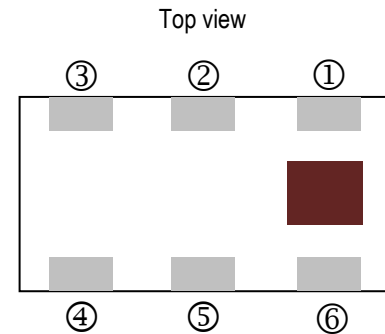

³ The termination type is Nickel Tin. Go to: <https://www.johansontechnology.com/tech-notes/typical-soldering-profile-ipc> for Typical Soldering Profile.

⁴ Use 1.0pF RF GND cap when using DC feed option.



Recommended PCB Layout

Note: Mount device with colored mark facing up.

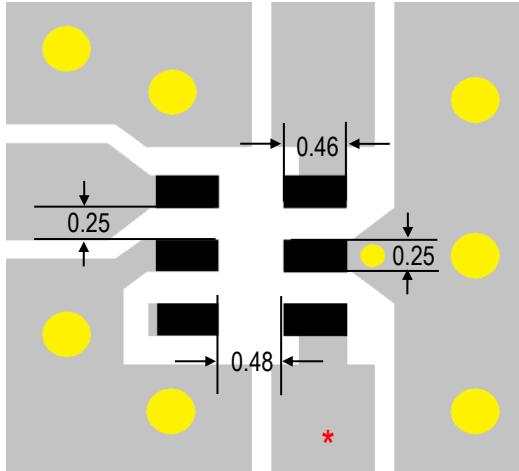
Without DC feed





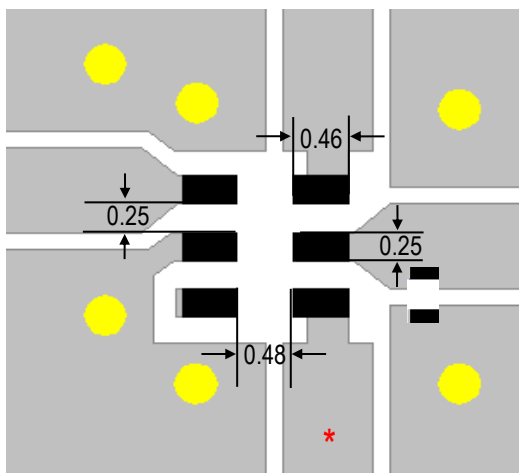

Units: mm

-  Solder Resist
-  Land
-  Through-hole (ϕ 0.35 / 0.18)

With DC feed⁵



-  Solder Resist
-  Land
-  Through-hole (ϕ 0.35)
-  Bypass 0201 capacitor (1.0 pF)

*Transmission line width should be designed to match 50 Ω characteristic impedance, depending on PCB material and thickness.

If you would like the full reference design package or have any questions, contact our application engineers at <https://www.johansontechnology.com/ask-a-question>

⁵ Bypass capacitor should be connected when feeding DC power.

Equivalent Internal Circuit^{6 7 8}

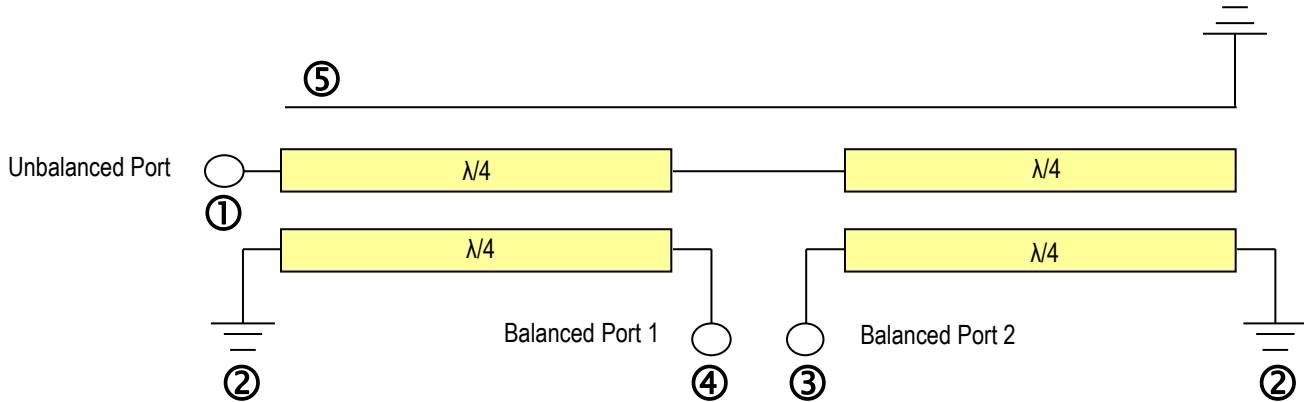

Measuring Diagram

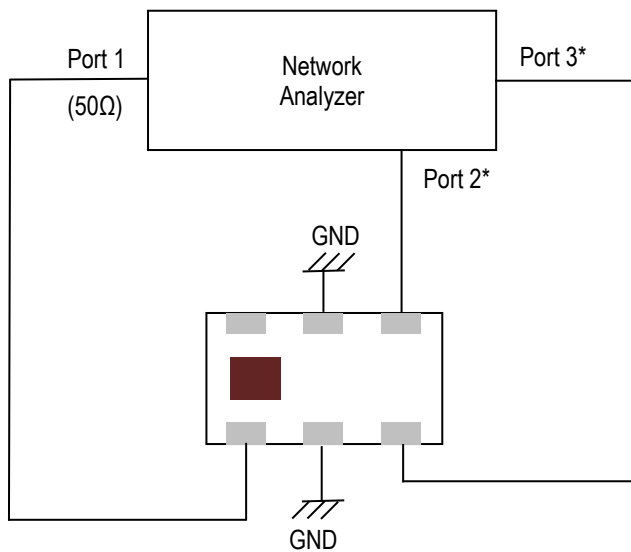

Port 1: Unbalanced Port

Ports 2 and 3: Balanced Port

Insertion Loss = S_{ds21}

Return Loss = S_{ss11}

Amplitude Balance = $\text{dB}(S(2,1)/S(3,1))$

Phase Balance = $\text{Phase}(S(2,1)/S(3,1))$

*Impedance for Ports 2 and 3 = Balanced Impedance/2

⁶ Pin3 and Pin4 are DC connected to Pin2 (GND or DC feed) in the device but not DC connected to Pin5 (GND). Therefore, by-pass capacitors should be connected when feeding DC power from Pin2. Recommended bypass capacitor: 1.0pF (EIA 0201).

⁷ Unbalanced port does not have a direct current path to GND.

⁸ Pin 6 is a floating pin (no internal connections) but it still must be soldered.



RF Measurement (T=25°C)

Insertion Loss, Return Loss and CMRR

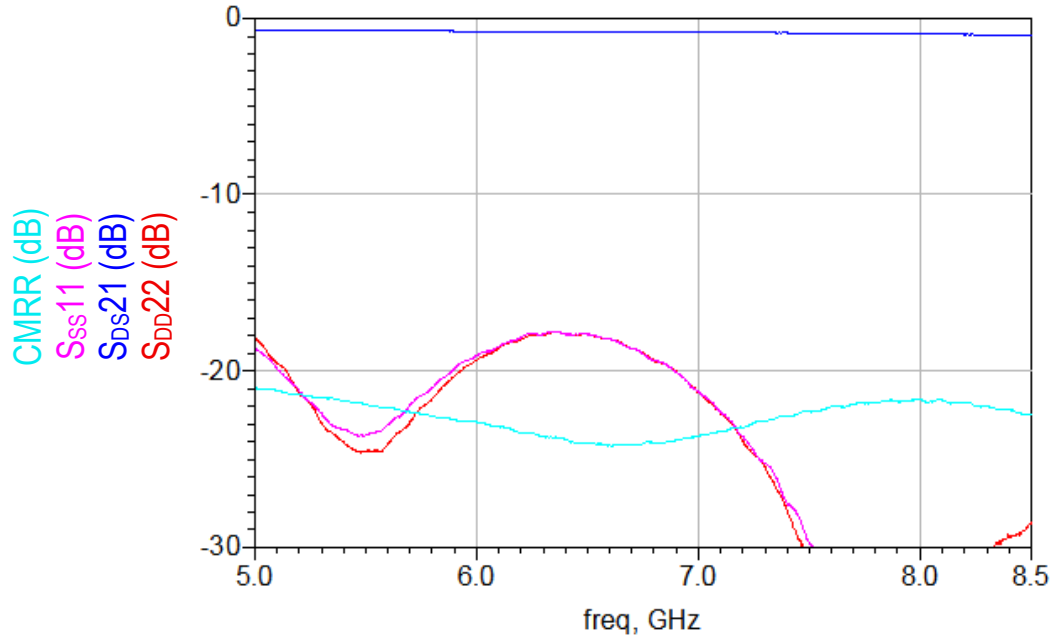

Phase Difference and Amplitude Difference

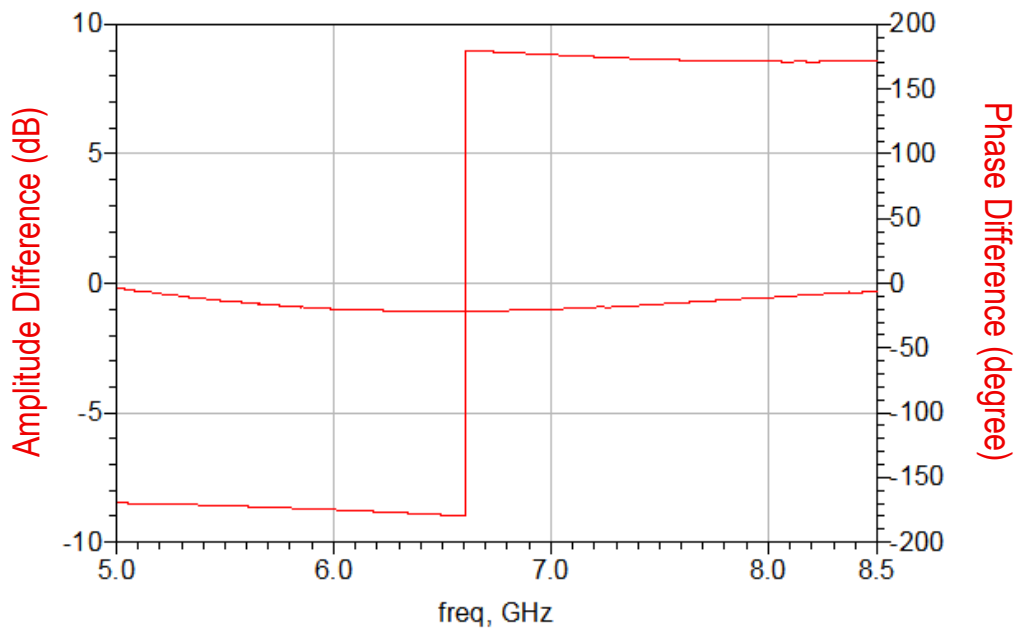

S-parameter and layout files available upon request. Please contact us at <https://www.johansontechnology.com/ask-a-question>

Tape and Reel Specifications (Units in mm)

Tape Dimensions

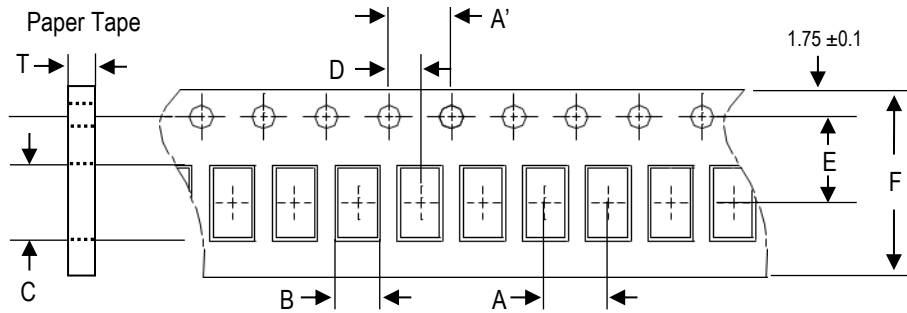

A	A'	B	C	D	E	F	T	Quantity/reel	Tape material
4.0 ±0.1	4.0 ±0.1	1.1 ±0.1	1.92 ±0.1	2.0 ±0.1	3.5 ±0.1	8.0 ±0.1	0.75 ±0.05	4,000 pcs.	Paper

Reel Dimensions

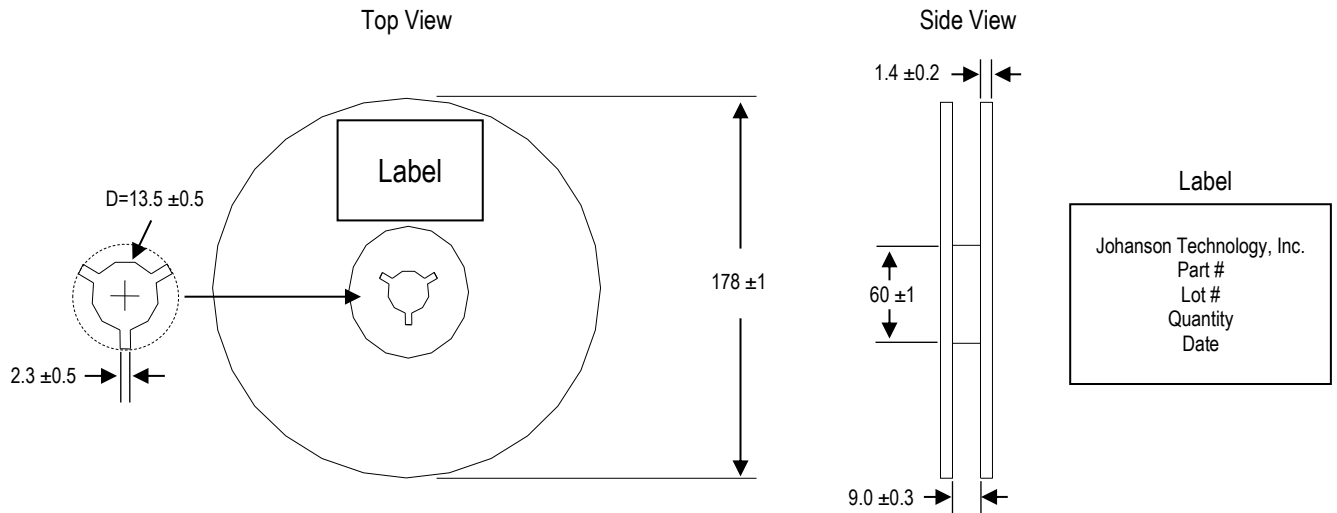

Leader and Trailer Dimensions

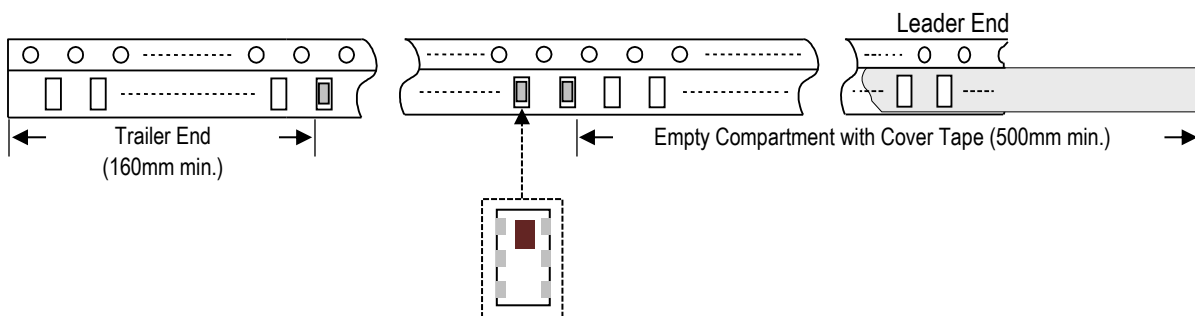

Orderable Part Numbers

Packaging Style	Part Number	Termination
Bulk (loose pcs.)	6750BL14A0050001B	Nickel Tin
T & R (7" Reel Paper Tape)	6750BL14A0050001T (Qty: 4,000 pcs./reel)	
Evaluation Board with 3 SMA Connector	6750BL14A0050001CE1 (Without DC feed)	

Important Links

[6750BL14A0050001T Product Page](#)

[More RF Baluns](#)

[Antenna Tuning, Optimization, and Validation Services](#)

[Soldering Information](#)

[MSL Information](#)

[Packaging Information](#)

[Recommended Storage Condition and Max Shelf Life](#)

[RoHS Compliance](#)

**Johanson Technology, Inc. reserves the right to make design changes without notice.
All sales are subject to Johanson Technology, Inc. terms and conditions.**