

6.75 GHz RF 1:2 Balun

- 5000 - 8500 MHz, 50:100 (1:2) Impedance Ratio
- Wireless communication systems Ultra-wide Band (UWB), including UNII
- SMD, EIA 0603
- RoHS compliant

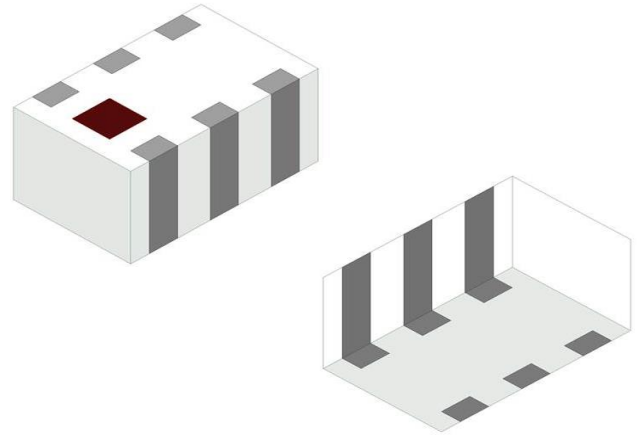

General Specifications^{1 2}

Passband Frequency (MHz)	5000 – 8500	5500 – 7200
Unbalanced Impedance (Ω)	50	50
Balanced Impedance (Ω)	100	100
Insertion Loss (dB)	0.7 Typ. (1.5 Max.)	0.64 Typ. (1.5 Max.)
Return Loss (dB)	11.7 Typ. (9.5 Min.)	12.6 Typ. (9.5 Min.)
Phase Difference (degree)	180 ± 13	180 ± 13
Amplitude Difference (dB)	± 1.25	± 1.25
CMRR (dB)	17.5 Min.	17.5 Min.

Maximum Ratings

Power Capacity (W)	3 Max. (CW)
DC Feed Current Rating (A)	1 Max.
Operating Temperature ($^{\circ}\text{C}$)	-40 to +85
Recommended Storage Conditions post-installation ($^{\circ}\text{C}$)	-40 to +85
Recommended Storage Conditions and Period for Unused T&R Product	45% - 75% RH +5 to +35 $^{\circ}\text{C}$ 18 Months Max.

¹ Typical value represents average measurement at 25 $^{\circ}\text{C}$. Min./Max. values represent measurements over specified operating temperature.

² General specifications measured on Johanson's evaluation board P/N 6750BL14A0100001CE1.

Mechanical Dimensions

	Inches			Millimeters		
L	0.063	±	0.004	1.60	±	0.10
W	0.031	±	0.004	0.80	±	0.10
T	0.024	±	0.004	0.60	±	0.10
a	0.008	±	0.004	0.20	±	0.10
b	0.008	±	0.006	0.20	±	0.15
c	0.006	±	0.004	0.15	±	0.10
g	0.012	±	0.004	0.30	±	0.10
p	0.020	±	0.002	0.50	±	0.05

Bottom view

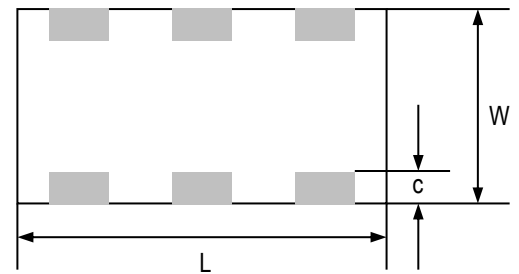

Side view

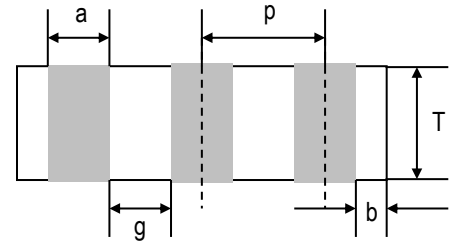

Terminal Configuration³

Pin Number	Function
1	Unbalanced Port (IN)
2 ⁴	GND or (DC feed + RF GND)
3	Balanced Port (OUT1)
4	Balanced Port (OUT2)
5	GND
6	NC

Top view

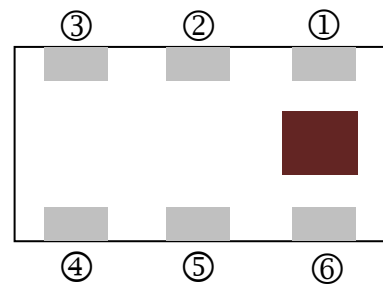

³ The termination type is Nickel Tin. Go to: <https://www.johansontechnology.com/tech-notes/typical-soldering-profile-ipc> for Typical Soldering Profile.

⁴ Use 1.0pF RF GND cap when using DC feed option.



Recommended PCB Layout

Note: Mount device with colored mark facing up.

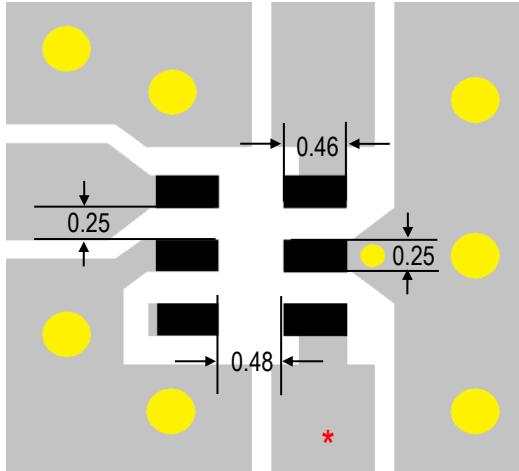
Without DC feed





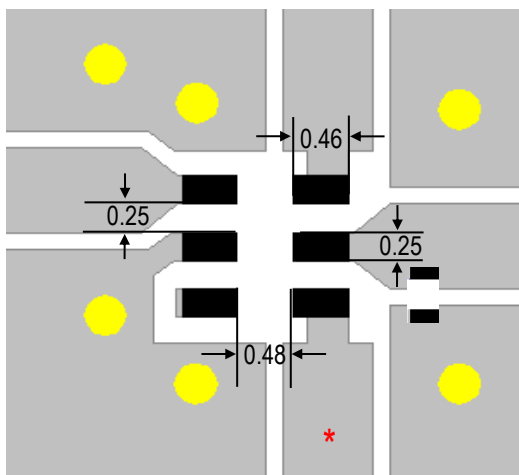

Units: mm

-  Solder Resist
-  Land
-  Through-hole (ϕ 0.35 / 0.18)

With DC feed⁵



-  Solder Resist
-  Land
-  Through-hole (ϕ 0.35)
-  Bypass 0201 capacitor (1.0 pF)

*Transmission line width should be designed to match 50 Ω characteristic impedance, depending on PCB material and thickness.

If you would like the full reference design package or have any questions, contact our application engineers at <https://www.johansontechnology.com/ask-a-question>

⁵ Bypass capacitor should be connected when feeding DC power.

Equivalent Internal Circuit^{6 7 8}

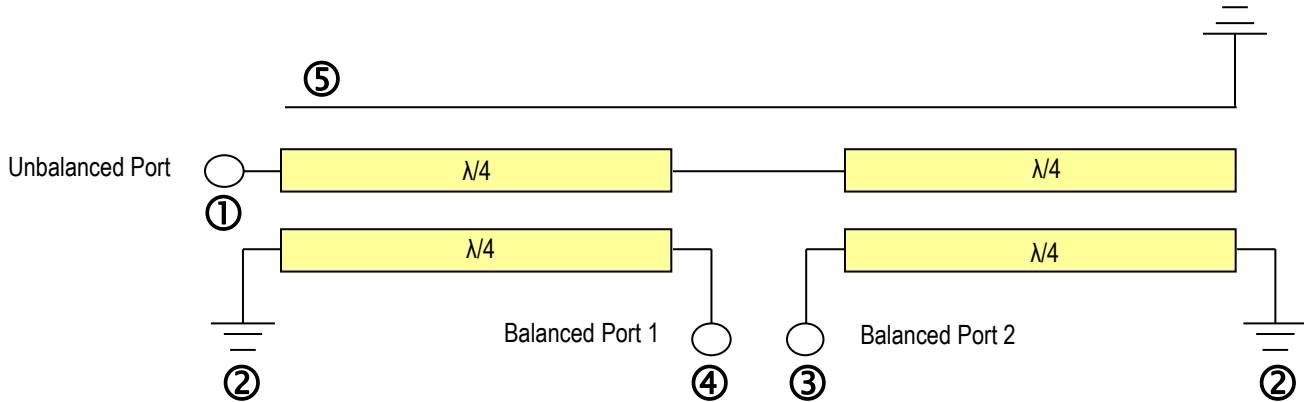

Measuring Diagram

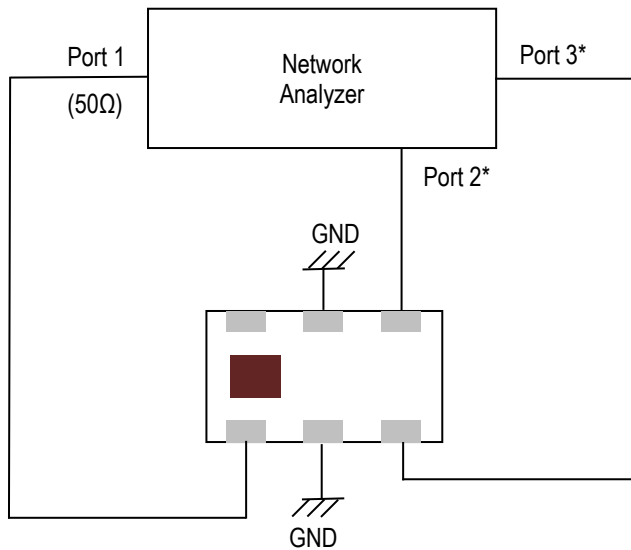

Port 1: Unbalanced Port

Ports 2 and 3: Balanced Port

Insertion Loss = S_{ds21}

Return Loss = S_{ss11}

Amplitude Balance = $\text{dB}(S(2,1)/S(3,1))$

Phase Balance = $\text{Phase}(S(2,1)/S(3,1))$

*Impedance for Ports 2 and 3 = Balanced Impedance/2

⁶ Pin3 and Pin4 are DC connected to Pin2 (GND or DC feed) in the device but not DC connected to Pin5 (GND). Therefore, by-pass capacitors should be connected when feeding DC power from Pin2. Recommended bypass capacitor: 1.0pF (EIA 0201).

⁷ Unbalanced port does not have a direct current path to GND.

⁸ Pin 6 is a floating pin (no internal connections) but it still must be soldered.



RF Measurement (T=25°C)

Insertion Loss, Return Loss and CMRR

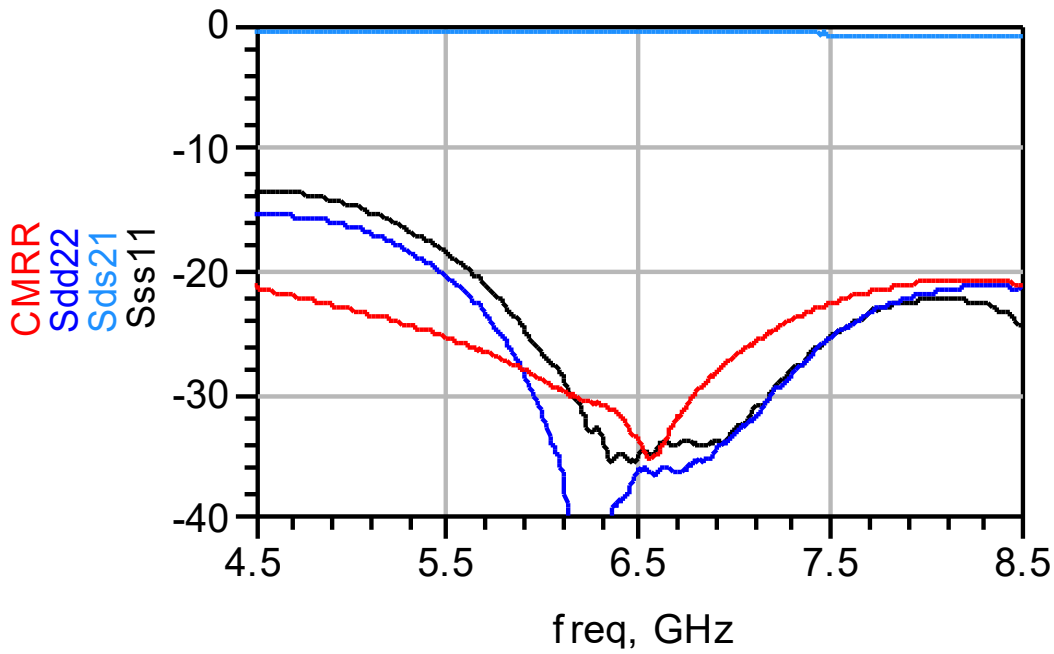

Phase Difference and Amplitude Difference

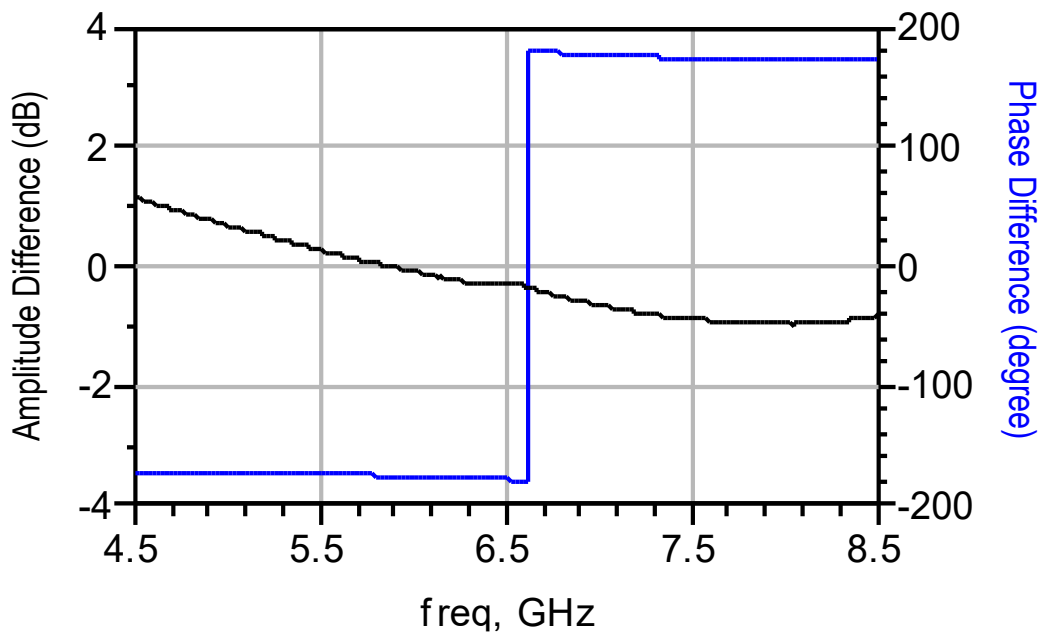

S-parameter and layout files available upon request. Please contact us at <https://www.johansontechnology.com/ask-a-question>

Tape and Reel Specifications (Units in mm)

Tape Dimensions

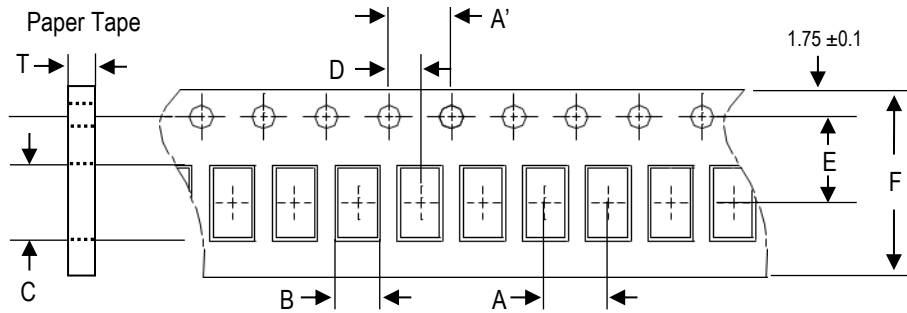

A	A'	B	C	D	E	F	T	Quantity/reel	Tape material
4.0 ±0.1	4.0 ±0.1	1.1 ±0.1	1.92 ±0.1	2.0 ±0.1	3.5 ±0.1	8.0 ±0.1	0.75 ±0.05	4,000 pcs.	Paper

Reel Dimensions

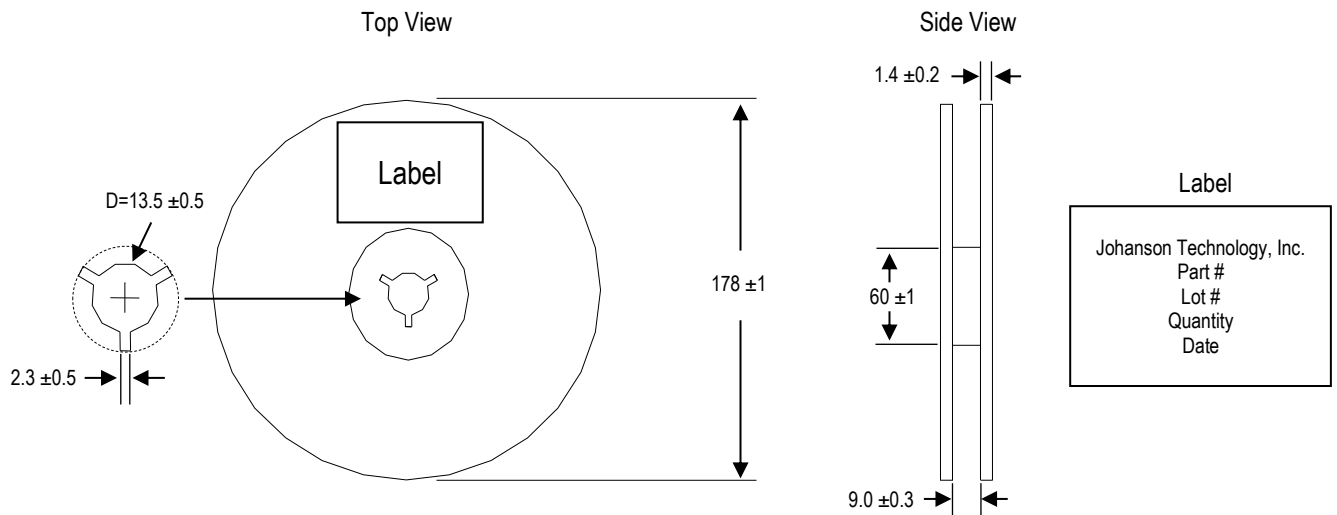

Leader and Trailer Dimensions

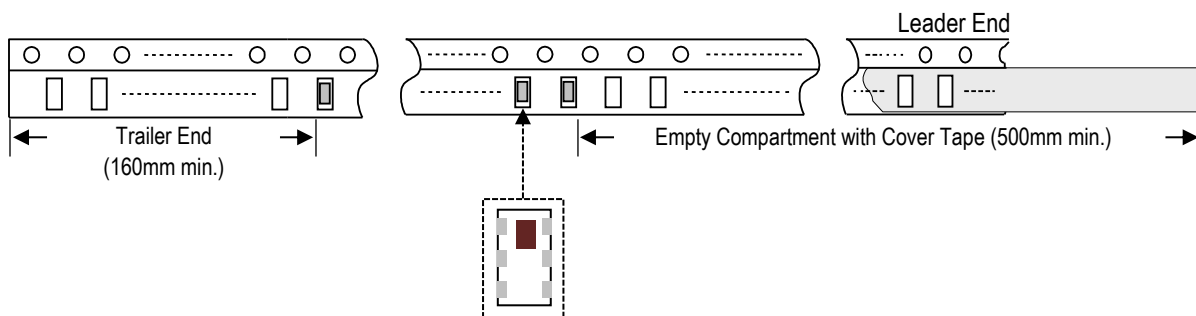

Orderable Part Numbers

Packaging Style	Part Number	Termination
Bulk (loose pcs.)	6750BL14A0100001B	Nickel Tin
T & R (7" Reel Paper Tape)	6750BL14A0100001T (Qty: 4,000 pcs./reel)	
Evaluation Board with 3 SMA Connector	6750BL14A0100001CE1 (Without DC feed)	

Important Links

[6750BL14A0100001T Product Page](#)

[More RF Baluns](#)

[Antenna Tuning, Optimization, and Validation Services](#)

[Soldering Information](#)

[MSL Information](#)

[Packaging Information](#)

[Recommended Storage Condition and Max Shelf Life](#)

[RoHS Compliance](#)

**Johanson Technology, Inc. reserves the right to make design changes without notice.
All sales are subject to Johanson Technology, Inc. terms and conditions.**