

2.45 GHz Band Pass Filter

- 2400 - 2500 MHz passband
- Fit for wireless communication systems: Bluetooth, WLAN, Hyper-LAN, etc.
- Low insertion loss
- High out-of-band rejection
- SMD, EIA 0805
- RoHS complaint

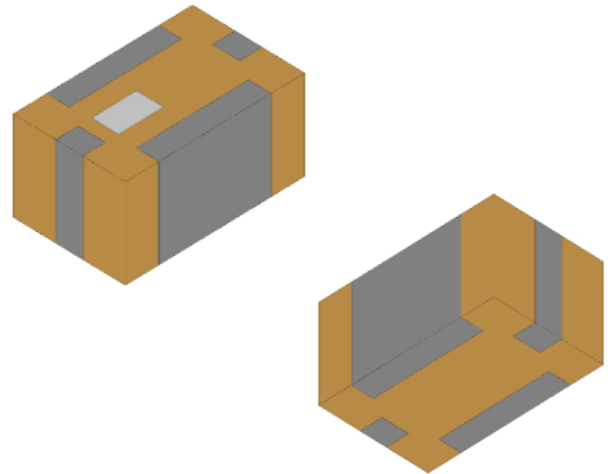

General Specifications^{1 2}

Insertion Loss (dB)	2400 - 2500 MHz	1.5 Max.
Return Loss (dB)	2400 - 2500 MHz	9.5 Min.
Attenuation (dB)	880 - 915 MHz	30 Min.
	1710 - 1785 MHz	30 Min.
	1850 - 1910 MHz	25 Min.
	3800 MHz	16 Min.
	4800 - 5000 MHz	25 Min.
	7200 - 7500 MHz	25 Min.

Maximum Ratings

Power Capacity (W)	2 Max. (CW)
Operating Temperature (°C)	-40 to +85
Recommended Storage Conditions post-installation (°C)	-40 to +85
Recommended Storage Conditions and Period for Unused T&R Product ³	45% - 75% RH +5 to +35 °C 18 Months Max.

¹ Typical value represents average measurement at 25°C. Min./Max. values represent measurements over specified operating temperature.

² General specifications measured on Johanson's evaluation board P/N 2450BP15E0100001CE1.

³ 18 months max. in vacuum sealed bag and 1 week after opened. Please keep unused parts in vacuum sealed bags. For more info go to <https://www.johansontechnology.com/tech-notes/silver-leaded-components-soldering-profile>.

Mechanical Dimensions

	Inches			Millimeters		
L	0.079	±	0.006	2.00	±	0.15
W	0.049	±	0.004	1.25	±	0.10
T	0.022	±	0.004	0.55	±	0.10
a	0.051	±	0.006	1.30	±	0.15
b	0.012	±	0.006	0.30	±	0.15
c	0.010	±	0.004	0.25	±	0.10
d	0.014	±	0.006	0.35	±	0.15

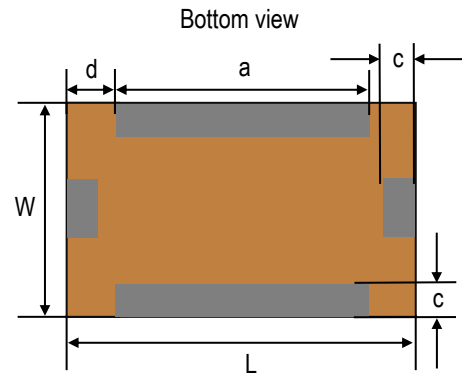

Side view

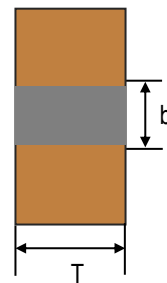

Top view

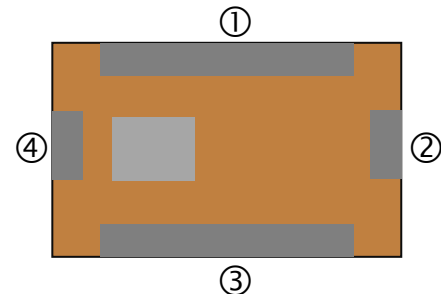

Terminal Configuration⁴

Pin Number	Function
1	GND
2	INPUT/OUTPUT
3	GND
4	INPUT/OUTPUT

⁴ The termination type is Silver. Go to <https://www.johansontechnology.com/tech-notes/silver-leaded-components-soldering-profile> for Typical Soldering Profile. SAC 305 solder paste recommended.



Recommended PCB Layout

Note: Mount device with colored mark facing up.

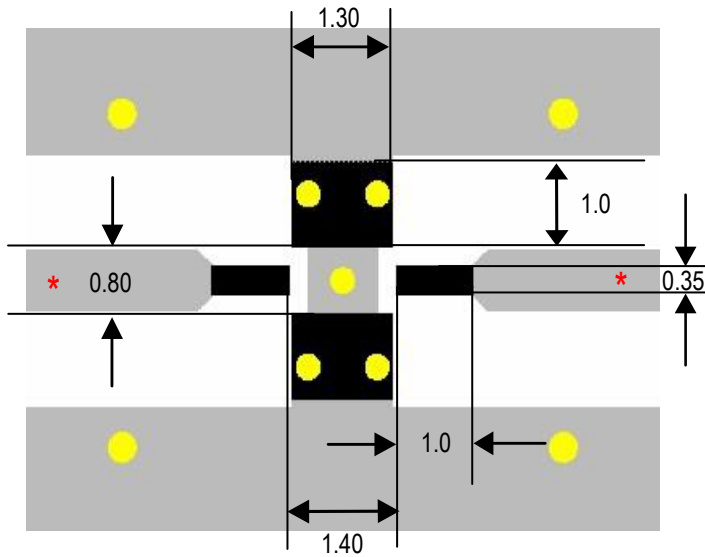

Units in mm

Solder Resist

Land

Through-hole (ϕ 0.35)

* Transmission line width should be designed to match 50Ω characteristic impedance, depending on PCB material and thickness.

If you'd like the CAD PCB layout or have any questions, contact our application engineers at <https://www.johansontechnology.com/ask-a-question>

Measuring Diagram



RF Measurement (T = 25°C)

Insertion Loss, Return Loss and Attenuation

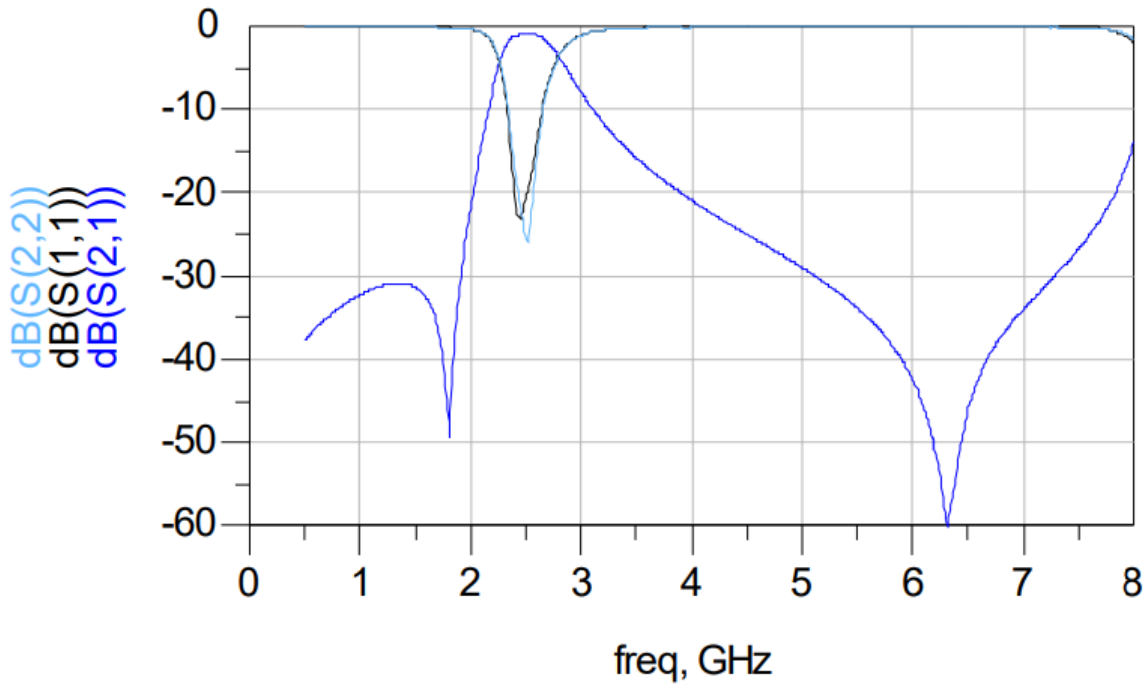

S-parameters, layout file, and complimentary design review are available upon request. Contact our application engineers at <https://www.johansontechnology.com/ask-a-question>

Tape and Reel Specification (Units in mm)

Tape Dimensions

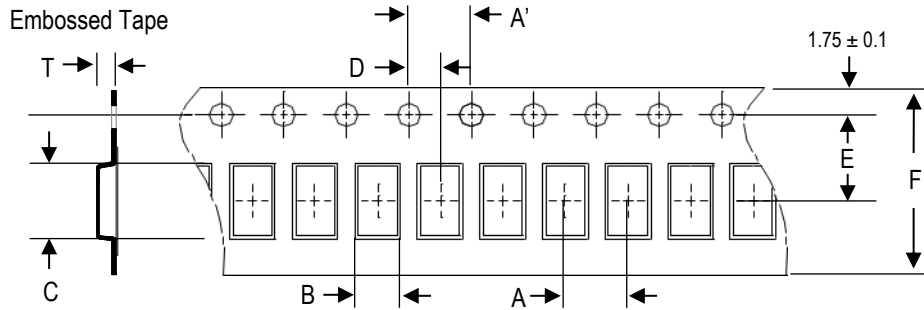

A	A'	B	C	D	E	F	T	Quantity/reel	Tape material
4.0 ±0.1	4.0 ±0.1	1.35 ±0.05	2.15 ±0.05	2.0 ±0.05	3.5 ±0.1	8.0 ±0.1	0.65 ±0.05	4,000 pcs.	Plastic (Embossed)

Reel Dimensions

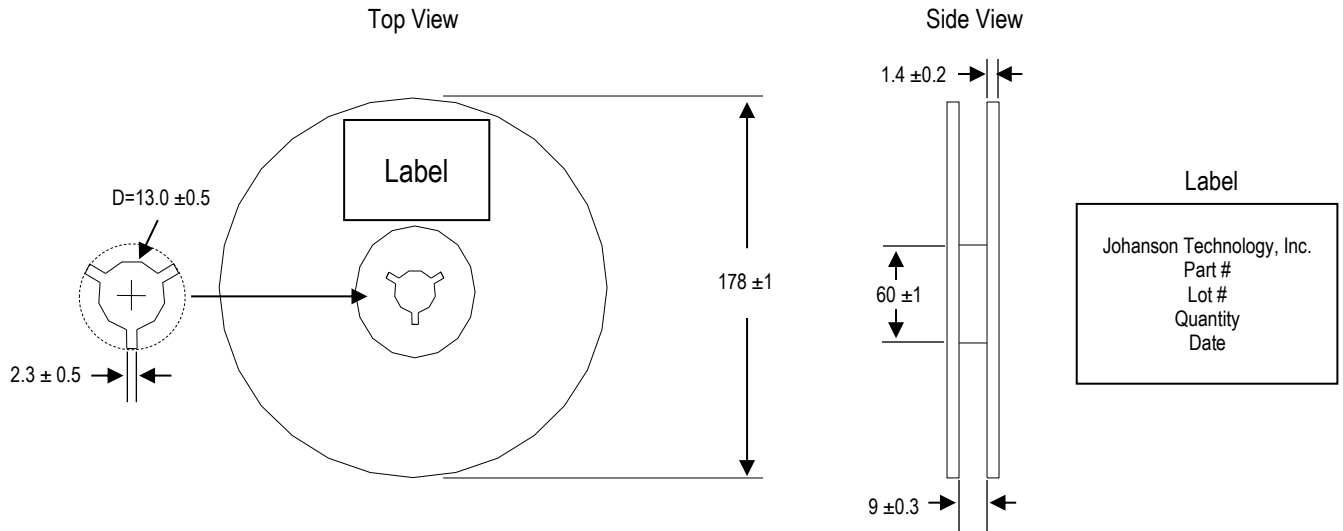

Leader and Trailer Dimensions

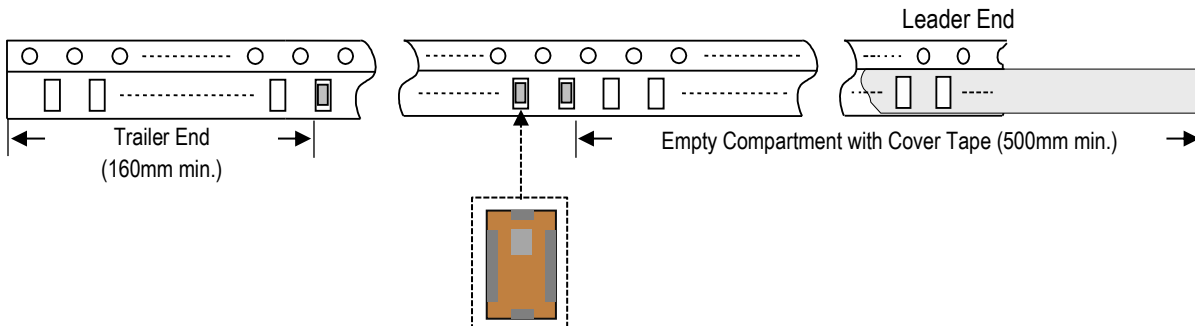

Orderable Part Number

Packaging Style	Part Number	Termination
Bulk (loose pcs.)	2450BP15E0100001B	Silver
T & R (7" Reel Embossed Tape)	2450BP15E0100001E (Qty: 4,000 pcs./reel)	
Evaluation Board with 2 SMA Connectors	2450BP15E0100001CE1	

Important Links

[2450BP15E0100001E Product Page](#)

[More Band Pass Filters](#)

[Antenna Tuning, Optimization, and Validation Services](#)

[Soldering Information](#)

[MSL Information](#)

[Packaging Information](#)

[Recommended Storage Condition and Max Shelf Life](#)

[RoHS Compliance](#)

Johanson Technology, Inc. reserves the right to make design changes without notice.

All sales are subject to Johanson Technology, Inc. terms and conditions.