

910 MHz Directional Coupler/Low Pass Filter Combination

- 860 - 960 MHz passband
- For wireless applications, such as ISM consumer Sub GHz, IoT smart home, cellular, LoRa®, etc.
- SMD, EIA 0805
- RoHS compliant

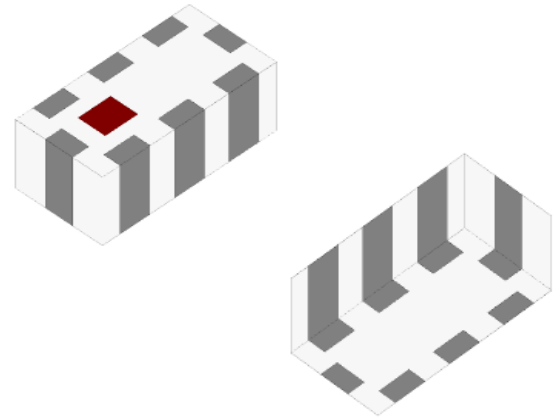

General Specifications^{1 2}

Impedance	860 - 960 MHz	50 Ω
Insertion Loss (dB)	860 - 960 MHz	1.2 Max.
Return Loss (dB)	860 - 960 MHz	20 Min.
Coupling (dB)	860 - 960 MHz	10 ± 1
Isolation (dB)	860 - 960 MHz	30 Min.
Attenuation (dB)	1720 - 1920 MHz	27 Min.
	2580 - 2880 MHz	30 Min.
	3440 - 3840 MHz	30 Min.
	4300 - 4800 MHz	30 Min.

Maximum Ratings

Power Capacity (W)	3 Max. (CW)
Operating Temperature (°C)	-40 to +85
Recommended Storage Conditions post-installation (°C)	-40 to +85
Recommended Storage Conditions and Period for Unused T&R Product	45% - 75% RH +5 to +35°C 18 Months Max.

¹ Typical value represents average measurement at 25°C. Min./Max. values represent measurements over specified operating temperature.

² General specifications measured on Johanson's evaluation board PN 0910CF15B0100001CE1.

Mechanical Dimensions

	Inches			Millimeters		
L	0.079	±	0.004	2.0	±	0.1
W	0.049	±	0.004	1.25	±	0.1
T	0.020	±	0.004	0.50	±	0.1
a	0.012	±	0.004	0.30	±	0.1
b	0.008	±	0.004	0.20	±	0.1
c	0.012	+0.004/-0.008		0.30	+0.1/-0.2	
g	0.014	±	0.004	0.35	±	0.10
p	0.026	±	0.002	0.65	±	0.05

Bottom view

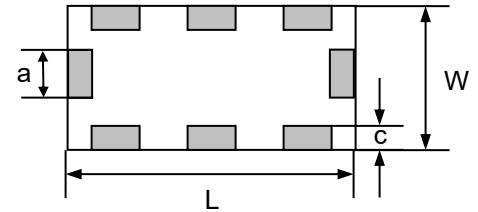

Side view

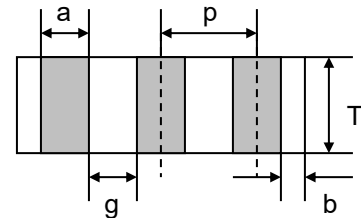

Terminal Configuration³

Pin Number	Function
1	TERMINATION
2	GND
3	GND
4	INPUT
5	COUPLED OUT
6	GND
7	GND
8	OUTPUT

Top view

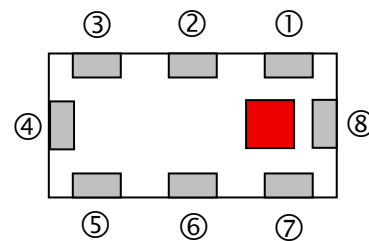

³ The termination type is Nickel Tin. Go to: <https://www.johansontechnology.com/tech-notes/typical-soldering-profile-ipc/> for Typical Soldering Profile.

Recommended PCB Layout

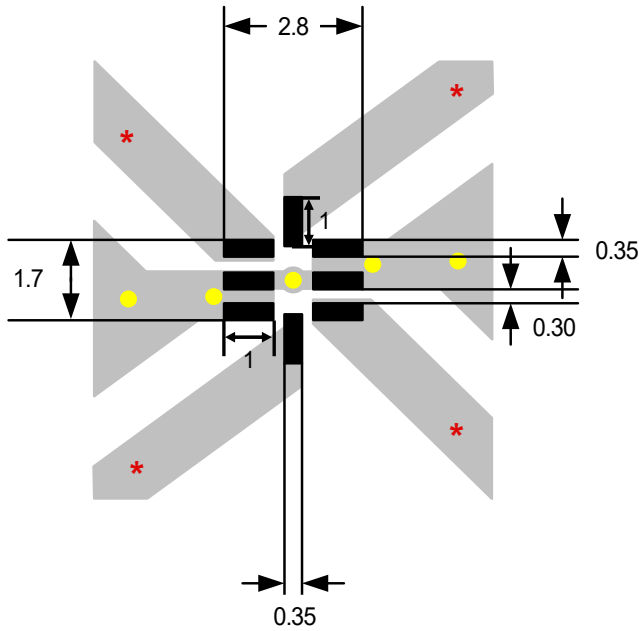

Units in mm

 Solder Resist

 Land

 Through-hole ($\phi 0.3$)

* Transmission line width should be designed to match 50 Ω characteristic impedance (CPWG preferred), depending on PCB material and thickness.

If you would like the full reference design package or have any questions, contact our application engineers at <https://www.johansontechnology.com/ask-a-question>

Measuring Diagram

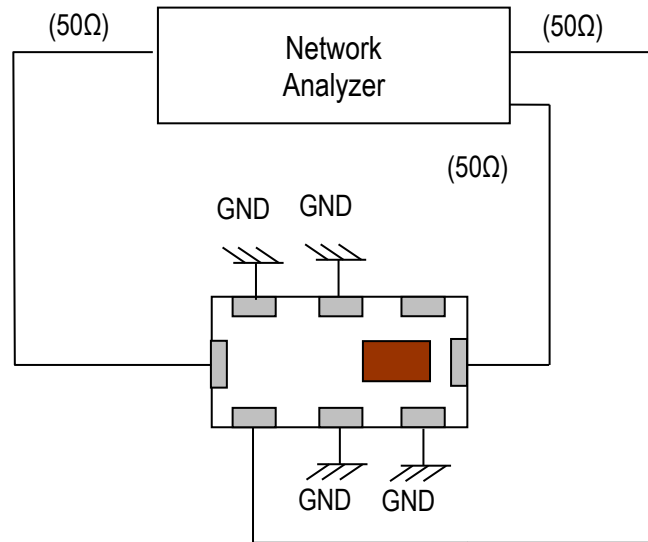



RF Measurement (T=25°C)

Insertion Loss

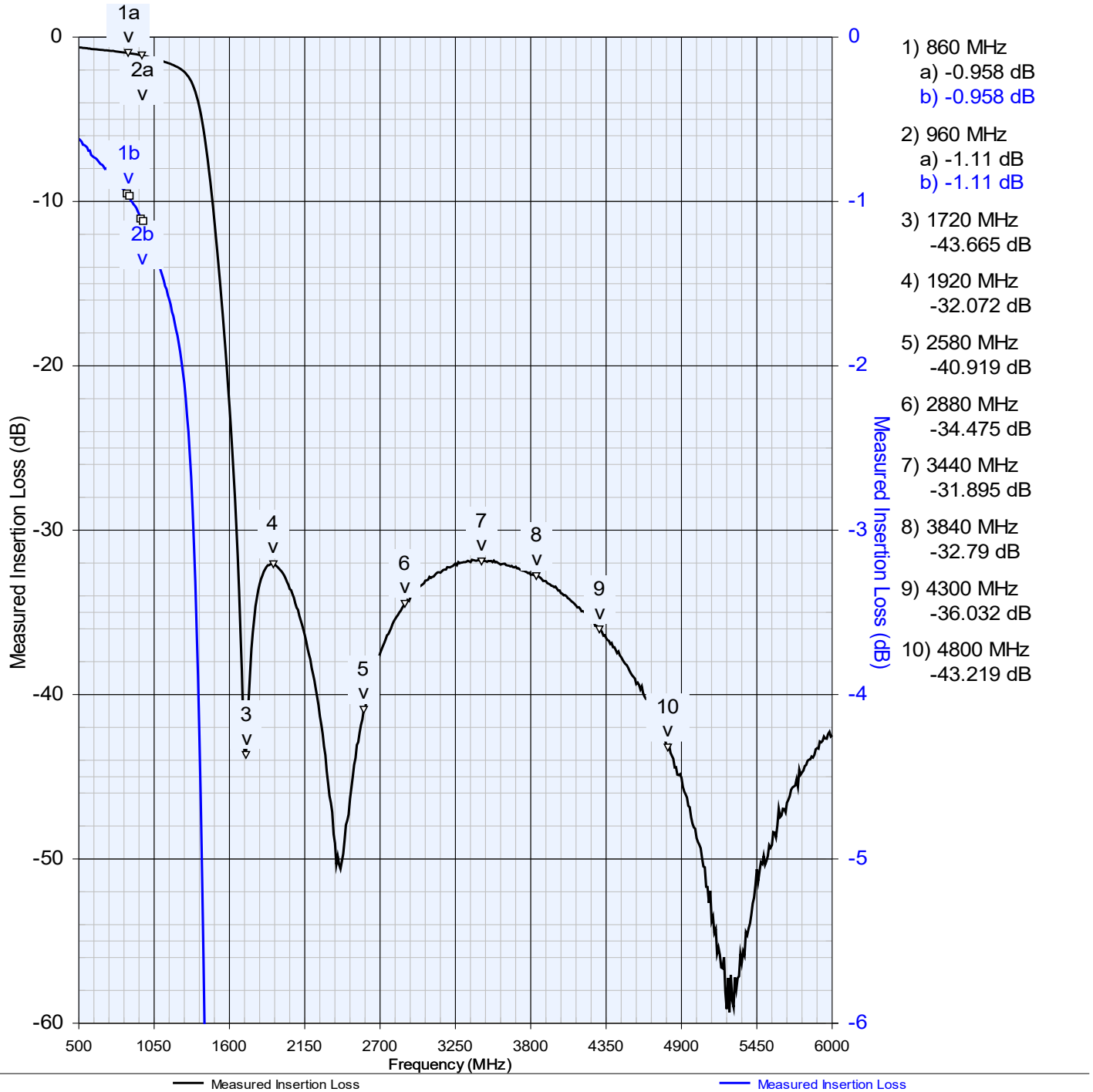



Return Loss

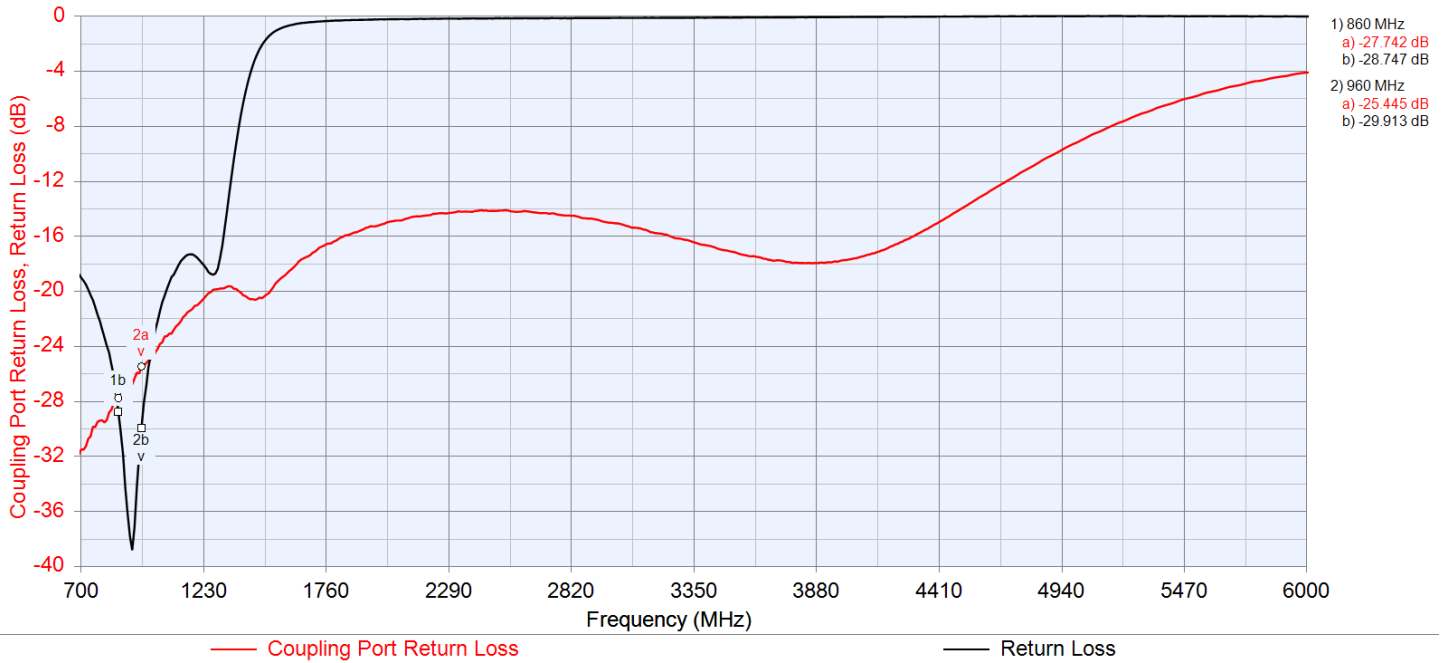

Coupling and Isolation

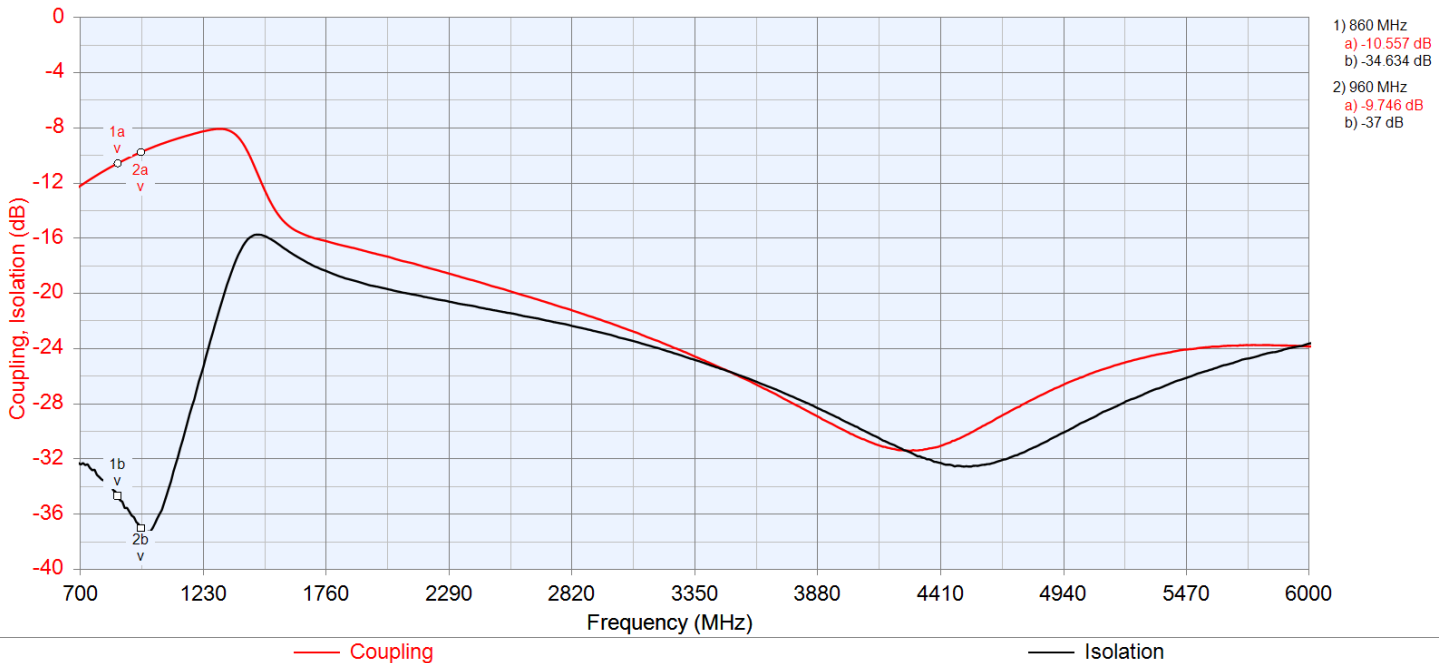

S-parameter and layout file available upon request, contact our application engineers at <https://www.johansontechnology.com/ask-a-question>



Tape and Reel Specifications (Units in mm)

Tape Dimensions

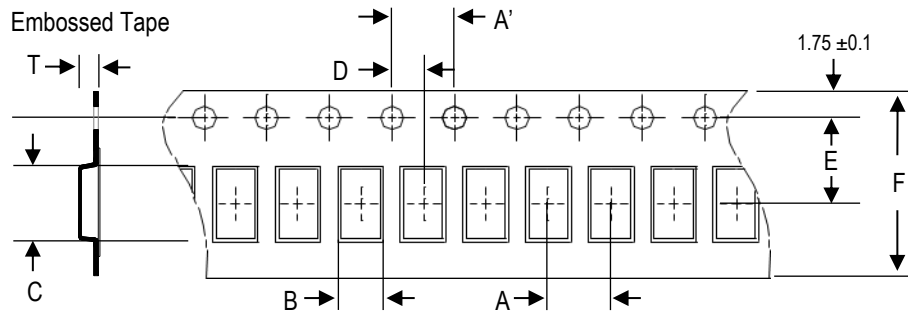

A	A'	B	C	D	E	F	T	Quantity/reel	Tape material
4.0 ±0.1	4.0 ±0.1	1.35 ±0.05	2.15 ±0.05	2.0 ±0.05	3.5 ±0.1	8.0 ±0.1	1.0 ±0.05	4,000pcs.	Plastic (Embossed)

Reel Dimensions

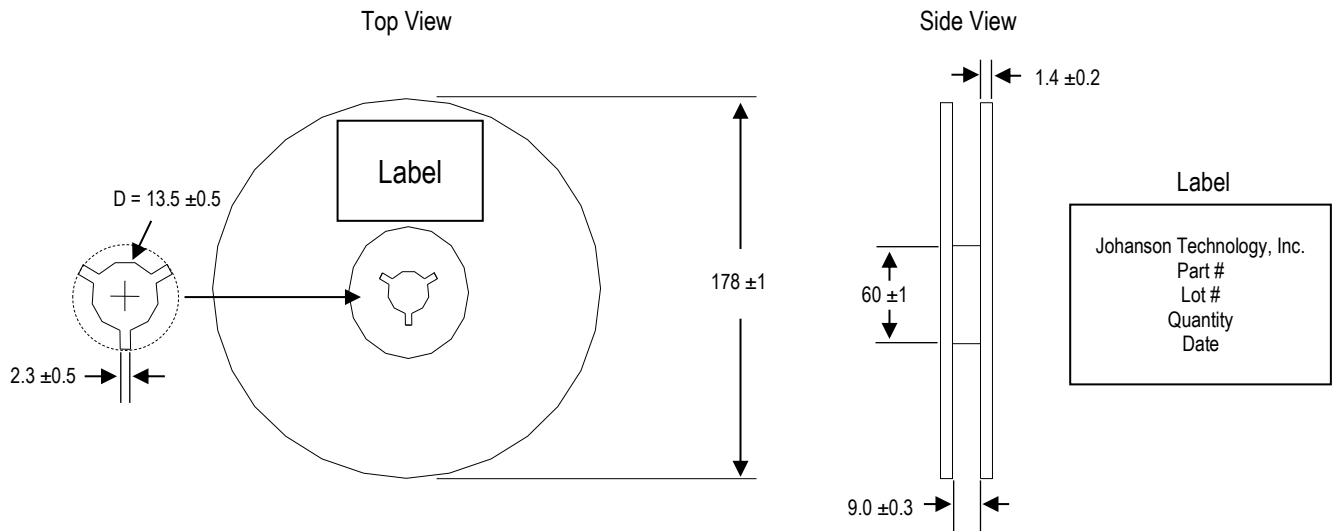

Leader and Trailer Dimensions

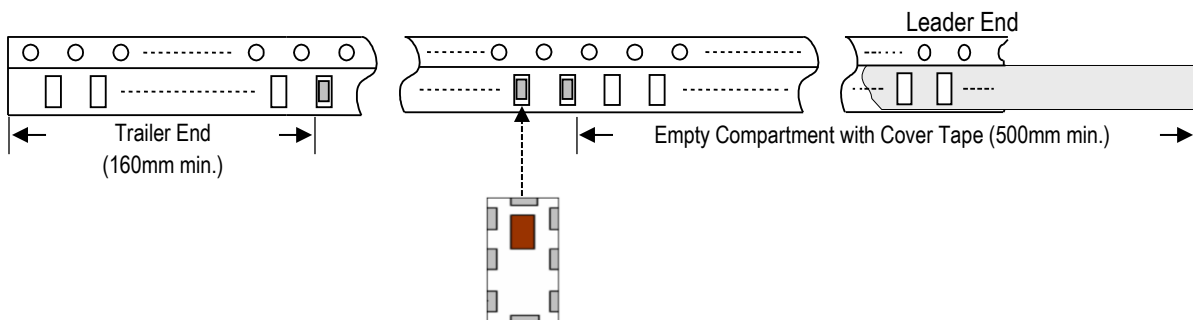

Orderable Part Numbers

Packaging Style	Part Number	Termination
Bulk (loose pcs.)	0910CF15B0100001B	Nickel Tin
T & R (7" Reel Embossed Tape)	0910CF15B0100001E (Qty: 4,000 pcs./reel)	
Evaluation Board with 4 SMA Connector	0910CF15B0100001CE1	

Important Links

[0910CF15B0100001E Product Page](#)

[More Couplers](#)

[More Low Pass Filters](#)

[Antenna Tuning, Optimization, and Validation Services](#)

[Soldering Information](#)

[MSL Information](#)

[Packaging Information](#)

[Recommended Storage Condition and Max Shelf Life](#)

[RoHS Compliance](#)

Contact our application engineers for a PCB layout review.

**Johanson Technology, Inc. reserves the right to make design changes without notice.
All sales are subject to Johanson Technology, Inc. terms and conditions.**