

402 – 405 MHz, 430 – 435 MHz Integrated Balun-filter for Texas Instruments Chipsets

- 402 – 405 MHz, 430 – 435 MHz ISM bands
- SMD, EIA 0805
- Complete front-end RF solution
 - Integrated impedance-matching balun and filter
 - Integrated harmonic filter for regulatory compliance
- Designed for use with Texas Instruments MCU chipsets and series:
 - CC110X, CC111X, CC113X, CC115X
 - CC110L, CC113L, CC115L
 - CC430, RF430

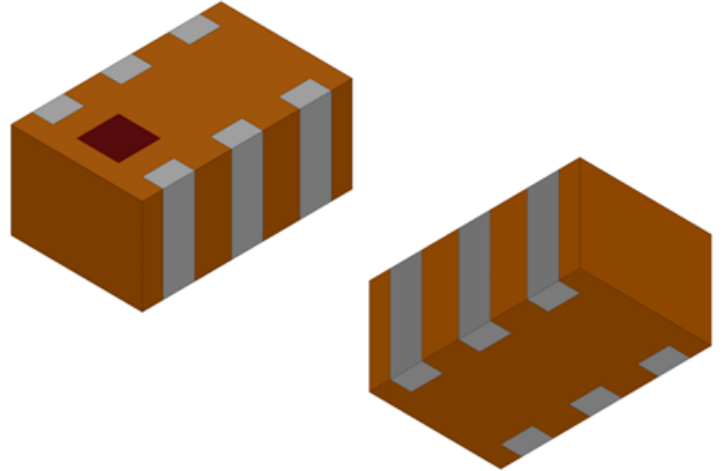

General Specifications¹

Passband Frequency (MHz)	402 – 405, 430 – 435	
Unbalanced Impedance, Antenna-side (Ω)	50	
Balanced Impedance, Transceiver-side (Ω)	Impedance-Matched to T.I. CC110X, CC111X, CC113X and CC115X; CC110L, CC113L and CC115L; CC430 and RF430 Chipsets	
Frequency Bands (MHz)	402 – 405	430 – 435
Insertion Loss (dB)	1.9 Max.	1.9 Max.
Return Loss (dB)	9.5 Min.	9.5 Min.
Phase Difference (Degree)	180 \pm 10	180 \pm 10
Amplitude Difference (dB)	3.0 Max.	1.5 Max.
Attenuation		
Frequency Range (MHz)	804 – 810	860 – 870
Attenuation (dB)	25 Min.	34 Min.
Frequency Range (MHz)	1206 – 1215	1290 – 1305
Attenuation (dB)	35 Min.	35 Min.
Frequency Range (MHz)	1608 – 1620	1720 – 1740
Attenuation (dB)	35 Min.	35 Min.
Frequency Range (MHz)	2010 – 2025	2150 – 2175
Attenuation (dB)	35 Min.	35 Min.

¹ Typical value represents average measurement at 25°C. Min./Max. values represent measurements over specified operating temperature.

Maximum Ratings

Power Capacity (W)	1 Max. (CW)
Operating Temperature (°C)	-40 to +85
Recommended Storage Conditions post-installation (°C)	-40 to +85
Recommended Storage Conditions and Period for Unused T&R Product ²	45% - 75% RH +5 to +35 °C 18 Months Max.

² 18 months max. in vacuum sealed bag and 1 week after opened. Please keep unused parts in vacuum sealed bags. For more info go to <https://www.johansontechnology.com/silverleads-profile>.

Mechanical Dimensions

	Inches			Millimeters		
L	0.079	±	0.004	2.00	±	0.10
W	0.049	±	0.004	1.25	±	0.10
T	0.028	±	0.004	0.70	±	0.10
a	0.012	±	0.004	0.30	±	0.10
b	0.008	±	0.004	0.20	±	0.10
c	0.012	+0.004/-0.008		0.30	+0.1/-0.2	
g	0.014	±	0.004	0.35	±	0.10
p	0.026	±	0.002	0.65	±	0.05

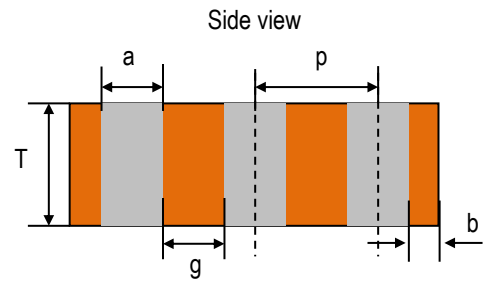
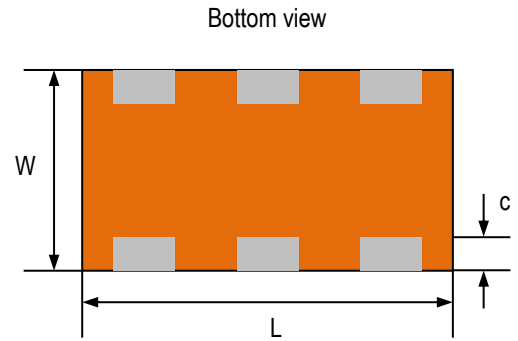

Terminal Configuration³

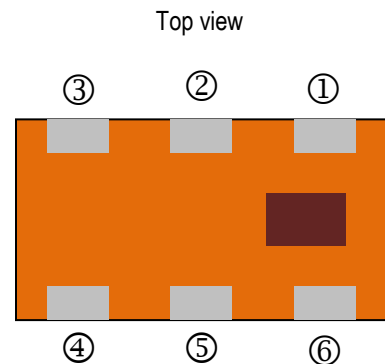

Pin Number	Function
1	Unbalanced
2	GND
3	Balanced Port
4	Balanced Port
5	GND
6	GND

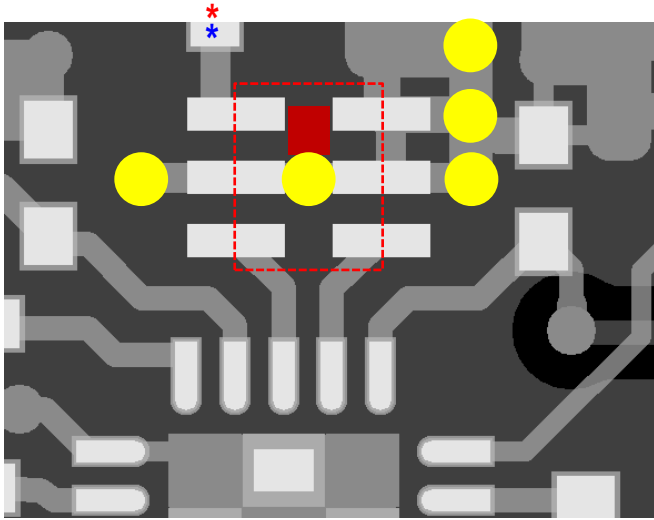

³ The termination type is Silver. Go to: <https://www.johansontechnology.com/ipcsoldering-profile> for Typical Soldering Profile.

PCB Reference Design Layout



-  Solder Resist
-  Solder Pads
-  GND Via

NOTE: GND via placement is crucial to the harmonic attenuation capability of the filter.

* DC-blocking capacitor embedded. External DC-blocking cap not necessary.

* Transmission line width should be designed to match 50Ω characteristic impedance, depending on PCB material and thickness.

We recommend designers to follow the official reference design in [Texas Instruments Design Note DN025](#).

Equivalent Integrated Circuit

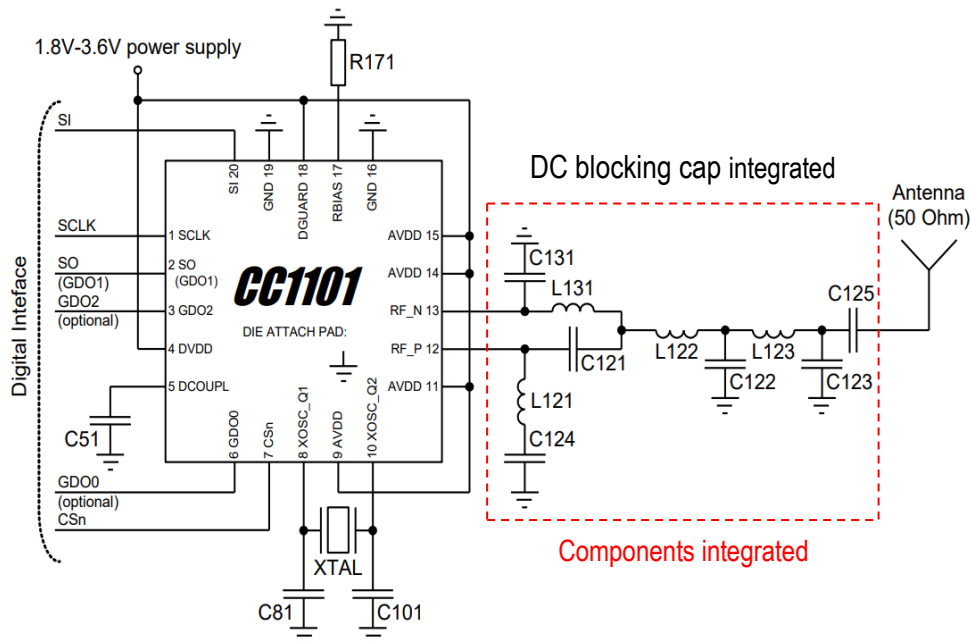

If you would like the full reference design package or have any questions, contact our application engineers at <https://www.johansontechnology.com/ask-a-question>

Measuring Diagram

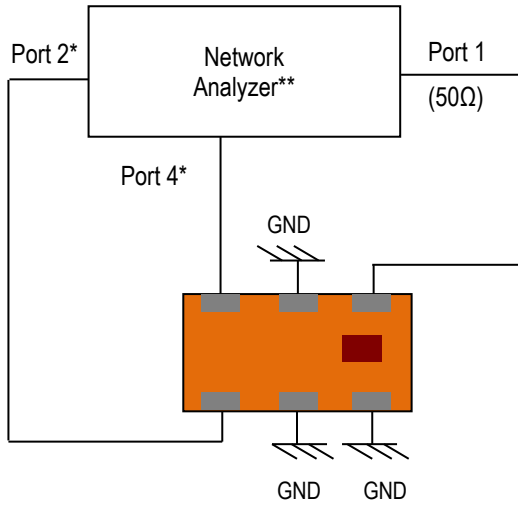

Port 1: Unbalanced

Ports 2 and 4: Balanced

Insertion Loss = S_{DS21}

Return Loss = S_{SS11}

Amplitude Difference = $\text{dB}(S(2,1)/S(4,1))$

Phase Difference = $\text{Phase}(S(2,1)/S(4,1))$

*Ports 2 and 4: Conjugate match to TI chipsets (Page 1)

** E5071B from Agilent



RF Measurement

Insertion Loss, Return Loss, Attenuation

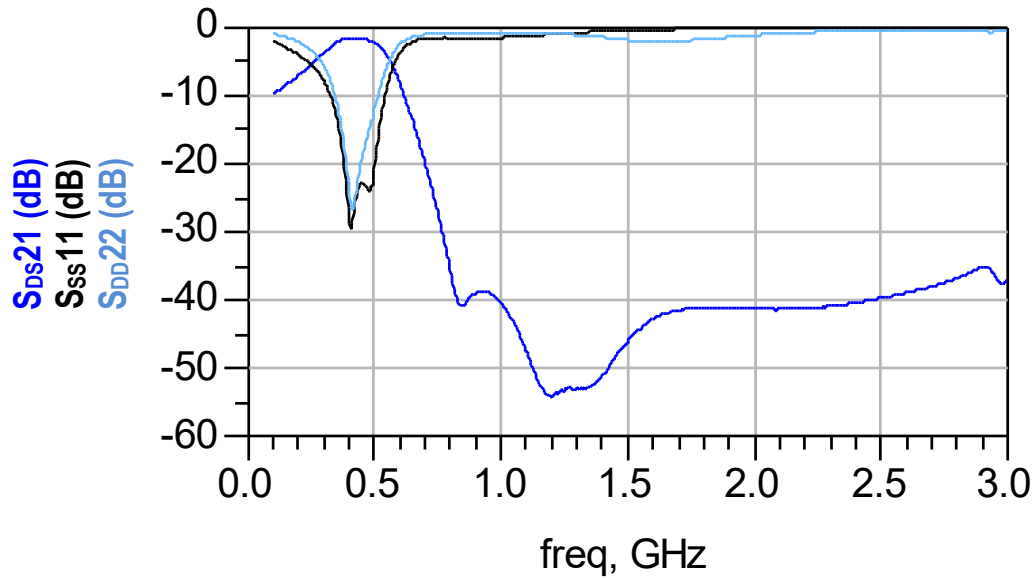

Phase Difference, Amplitude Difference

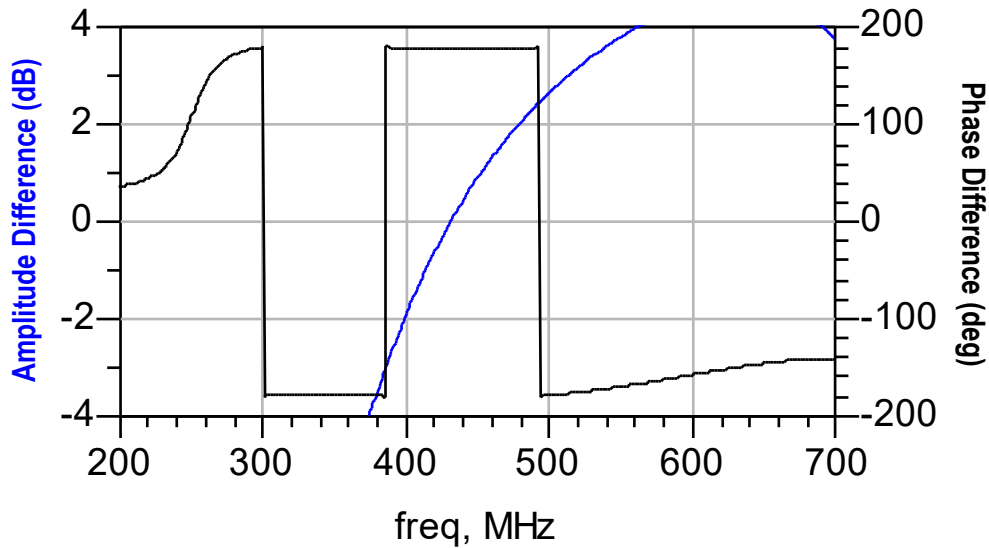

S-parameter and layout files available upon request. Please contact us at: <https://www.johansontechnology.com/ask-a-question>

Tape and Reel Specification (Units in mm)

Tape Dimensions

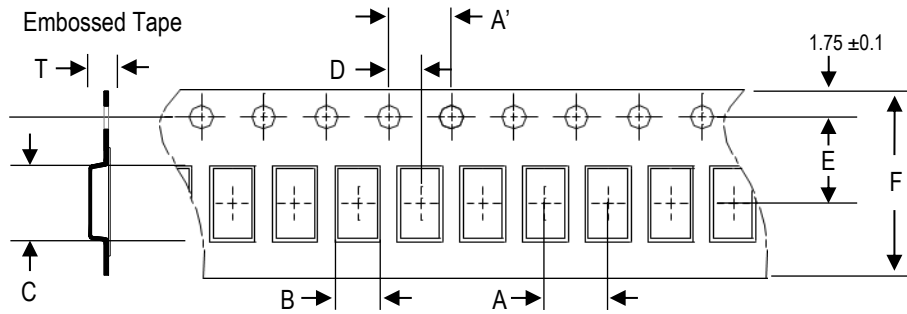

A	A'	B	C	D	E	F	T	Quantity/reel	Tape material
4.0 ± 0.1	4.0 ± 0.1	1.35 ± 0.05	2.15 ± 0.05	2.0 ± 0.05	3.5 ± 0.1	8.0 ± 0.1	1.00 ± 0.05	4,000 pcs	Plastic (Embossed)

Reel Dimensions

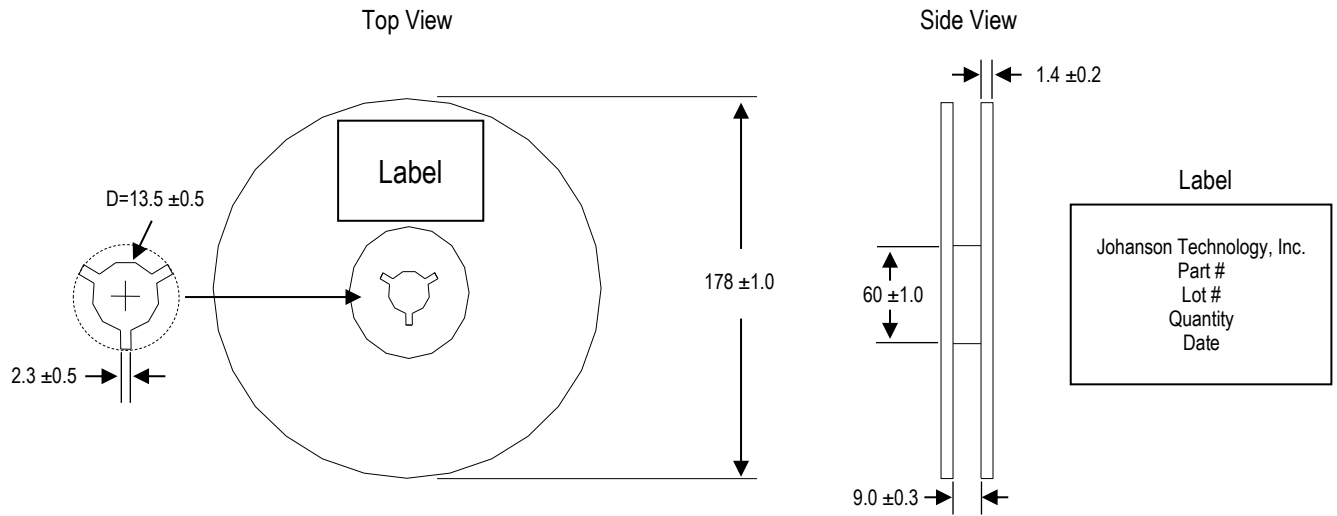

Leader and Trailer Dimensions

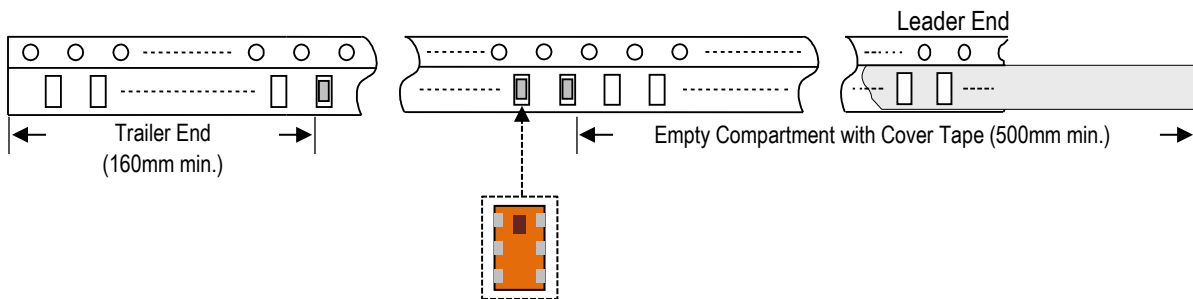

Orderable Part Number

Packaging Style	Part Number	Termination
Bulk (loose pcs.)	0433BM15A0001001B	Silver
T & R (7" Reel Embossed Tape)	0433BM15A0001001E (Qty: 4,000 pcs/reel)	

Important Links

[0433BM15A0001001E Product Page](#)

[Texas Instruments Design Note DN025](#)

[Antenna Tuning, Optimization, and Validation Services](#)

[Soldering Information](#)

[MSL Information](#)

[Packaging Information](#)

[Recommended Storage Condition and Max Shelf Life](#)

[RoHS Compliance](#)

Contact our application engineers for a PCB layout review.

Johanson Technology, Inc. reserves the right to make design changes without notice.

All sales are subject to Johanson Technology, Inc. terms and conditions.